

## Features

- Ultra High Efficiency (Up to 93.0%)
- Full Power at Wide Output Current Range (Constant Power)
- 0-5V/0-10V/PWM/Timer Dimmable
- Input Surge Protection: 6kV line-line, 10kV line-earth
- All-Around Protection: OVP, SCP, OTP
- Waterproof (IP67)
- SELV Output
- Suitable for Independent Use
- 7 Years Warranty



## Description

The EUG-096SxxxDV series is a 96W, constant-current, programmable LED driver that operates from 90-305 Vac input with excellent power factor. It is created for many lighting applications including low bay, tunnel and street lights. The high efficiency of these drivers and compact metal case enables them to run cooler, significantly improving reliability and extending product life. To ensure trouble-free operation, protection is provided against input surge, output over voltage, short circuit, and over temperature.

## Models

| Adjustable Output Current Range | Full-Power Current Range (1) | Default Output Current | Input Voltage Range(2)        | Output Voltage Range | Max. Output Power | Typical Efficiency (3) | Power Factor |        | Model Number                 |
|---------------------------------|------------------------------|------------------------|-------------------------------|----------------------|-------------------|------------------------|--------------|--------|------------------------------|
|                                 |                              |                        |                               |                      |                   |                        | 120Vac       | 220Vac |                              |
| 45-700mA                        | 450-700mA                    | 530 mA                 | 90 ~ 305 Vac<br>100 ~ 250 Vdc | 74~213Vdc            | 96 W              | 92.0%                  | 0.99         | 0.96   | EUG-096S070DV                |
| 70-1050mA                       | 700-1050mA                   | 700 mA                 | 90 ~ 305 Vac<br>100 ~ 250 Vdc | 48~137Vdc            | 96 W              | 93.0%                  | 0.99         | 0.96   | EUG-096S105DV                |
| 140-2100mA                      | 1400-2100mA                  | 2100 mA                | 90 ~ 305 Vac<br>100 ~ 250 Vdc | 24 ~ 69Vdc           | 96 W              | 92.0%                  | 0.99         | 0.96   | EUG-096S210DV <sup>(4)</sup> |
| 245-3500mA                      | 2450-3500mA                  | 2800 mA                | 90 ~ 305 Vac<br>100 ~ 250 Vdc | 14 ~ 39Vdc           | 96 W              | 91.0%                  | 0.99         | 0.96   | EUG-096S350DV <sup>(4)</sup> |

- Notes:** (1) Output current range with constant power at 96W  
 (2) Certified input voltage range: 100-240Vac or 100-250Vdc (except CCC, PSE, KS and BIS).  
 (3) Measured at full load and 220Vac input (see below "General Specifications" for details).  
 (4) SELV Output.

## I-V Operation Area

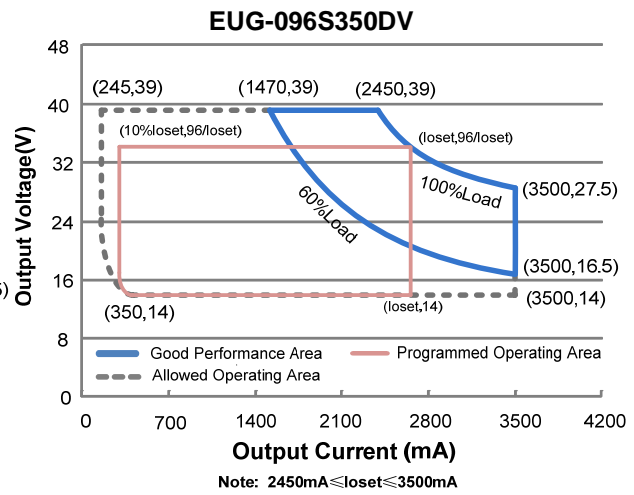
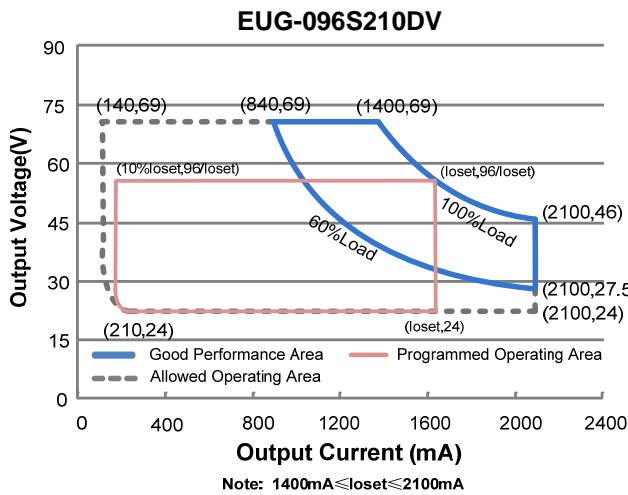
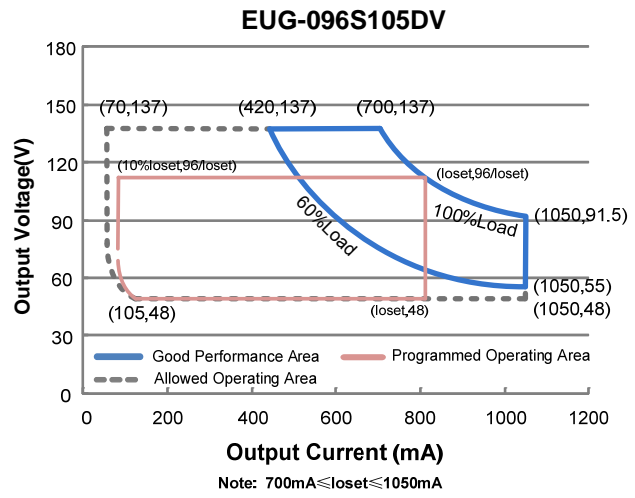
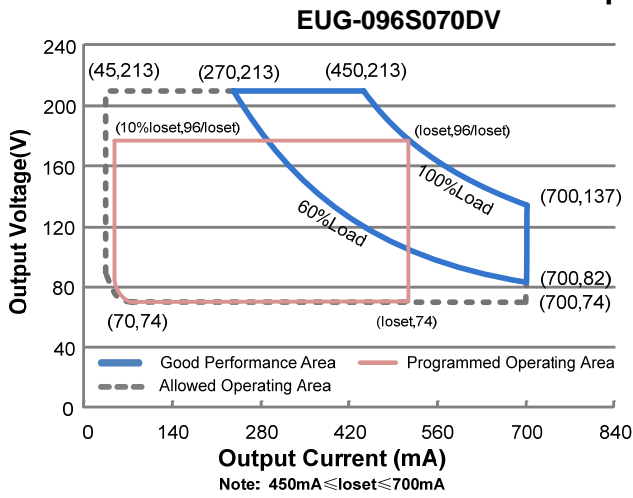

## Input Specifications

| Parameter                        | Min.   | Typ. | Max.                  | Notes  |
|----------------------------------|--------|------|-----------------------|--|
| Input Voltage                    | 90 Vac | -    | 305 Vac               | 100-250Vdc   |
| Input Frequency                  | 47 Hz  | -    | 63 Hz                 |  |
| Leakage Current                  | -      | -    | 0.70 mA               | IEC60598-1; 240Vac/ 60Hz   |
| Input AC Current                 | -      | -    | 1.32 A                | Measured at full load and 100 Vac input.   |
|                                  | -      | -    | 0.60 A                | Measured at full load and 220 Vac input.   |
| Inrush Current(I <sup>2</sup> t) | -      | -    | 1.65 A <sup>2</sup> s | At 220Vac input, 25°C cold start, duration=760 μs, 10%Ipk-10%Ipk. See Inrush Current Waveform for the details. |
| PF                               | 0.9    | -    | -                     | At 100-240Vac, 50-60Hz, 60%-100% Load (58-96W)   |
| THD                              | -      | -    | 20%                   |  |
| THD                              | -      | -    | 10%                   | At 220-240Vac, 50-60Hz, 75%-100% Load (72-96W)   |

## Output Specifications

| Parameter  | Min.     | Typ.     | Max.     | Notes   |
|--|----------|----------|----------|---|
| Output Current Tolerance                         | -5%loset | -        | 5%loset  | At full load condition  |
| Output Current Setting(loset) Range              |          |          |          |   |
| EUG-096S070DV                                    | 45 mA    | -        | 700 mA   |   |
| EUG-096S105DV                                    | 70 mA    | -        | 1050 mA  |   |
| EUG-096S210DV                                    | 140 mA   | -        | 2100 mA  |   |
| EUG-096S350DV                                    | 245 mA   | -        | 3500 mA  |   |
| Output Current Setting Range with Constant Power |          |          |          |   |
| EUG-096S070DV                                    | 450 mA   | -        | 700 mA   |   |
| EUG-096S105DV                                    | 700 mA   | -        | 1050 mA  |   |
| EUG-096S210DV                                    | 1400 mA  | -        | 2100 mA  |   |
| EUG-096S350DV                                    | 2450 mA  | -        | 3500 mA  |   |
| Total Output Current Ripple (pk-pk)              | -        | 5%lomag  | 10%lomag | At full load condition, 20 MHz BW   |
| Output Current Ripple at < 200 Hz (pk-pk)        | -        | 2%lomag  | -        | At full load condition. Only this component of ripple is associated with visible flicker. |
| Startup Overshoot Current                        | -        | -        | 10%lomag | At full load condition  |
| No Load Output Voltage                           |          |          |          |   |
| EUG-096S070DV                                    | -        | -        | 280 V    |   |
| EUG-096S105DV                                    | -        | -        | 180 V    |   |
| EUG-096S210DV                                    | -        | -        | 90 V     |   |
| EUG-096S350DV                                    | -        | -        | 50 V     |   |
| Line Regulation                                  | -        | -        | ±0.5%    | Measured at full load   |
| Load Regulation                                  | -        | -        | ±1.5%    |   |
| Turn-on Delay Time                               | -        | -        | 1.0 s    | Measured at 120Vac input, 60%-100% Load.  |
|  | -        | -        | 0.5 s    | Measured at 220Vac input, 60%-100% Load.  |
| Temperature Coefficient of loset                 | -        | 0.03%/°C | -        | Case temperature = 0°C ~Tc max  |
| 12V Auxiliary Output Voltage                     | 10.8 V   | 12 V     | 13.2 V   |   |
| 12V Auxiliary Output Source Current              | 0 mA     | -        | 20 mA    | Return terminal is "Dim"  |

**Note:** All specifications are typical at 25°C unless otherwise stated.

## General Specifications

| Parameter                    | Min.  | Typ.  | Max. | Notes |
|------------------------------|-------|-------|------|-------|
| Efficiency at 120 Vac input: |       |       |      |       |
| EUG-096S070DV                |       |       |      |       |
| lo= 450mA                    | 87.0% | 90.0% | -    |       |
| lo= 700mA                    | 86.0% | 89.0% | -    |       |
| EUG-096S105DV                |       |       |      |       |
| lo= 700mA                    | 88.5% | 91.5% | -    |       |
| lo=1050mA                    | 87.0% | 90.0% | -    |       |
| EUG-096S210DV                |       |       |      |       |
| lo=1400mA                    | 87.0% | 90.0% | -    |       |
| lo=2100mA                    | 87.0% | 90.0% | -    |       |
| EUG-096S350DV                |       |       |      |       |
| lo=2450mA                    | 86.0% | 89.0% | -    |       |
| lo=3500mA                    | 85.5% | 88.5% | -    |       |

## General Specifications (Continued)

| Parameter  | Min.   | Typ.   | Max.                                 | Notes  |
|--|--|--|--------------------------------------|--|
| Efficiency at 220 Vac input:<br>EUG-096S070DV<br>I <sub>o</sub> = 450mA<br>I <sub>o</sub> = 700mA<br>EUG-096S105DV<br>I <sub>o</sub> = 700mA<br>I <sub>o</sub> =1050mA<br>EUG-096S210DV<br>I <sub>o</sub> =1400mA<br>I <sub>o</sub> =2100mA<br>EUG-096S350DV<br>I <sub>o</sub> =2450mA<br>I <sub>o</sub> =3500mA | 90.0%<br>89.0%<br>91.0%<br>89.0%<br>89.5%<br>90.0%<br>89.0%<br>88.0% | 92.0%<br>91.0%<br>93.0%<br>91.0%<br>91.5%<br>92.0%<br>91.0%<br>90.0% | -<br>-<br>-<br>-<br>-<br>-<br>-<br>- | Measured at full load and steady-state temperature in 25°C ambient; (Efficiency will be about 2.0% lower if measured immediately after startup.) |
| Efficiency at 277 Vac input:<br>EUG-096S070DV<br>I <sub>o</sub> = 450mA<br>I <sub>o</sub> = 700mA<br>EUG-096S105DV<br>I <sub>o</sub> = 700mA<br>I <sub>o</sub> =1050mA<br>EUG-096S210DV<br>I <sub>o</sub> =1400mA<br>I <sub>o</sub> =2100mA<br>EUG-096S350DV<br>I <sub>o</sub> =2450mA<br>I <sub>o</sub> =3500mA | 90.5%<br>89.0%<br>91.5%<br>89.5%<br>90.0%<br>90.5%<br>89.5%<br>88.5% | 92.5%<br>91.0%<br>93.5%<br>91.5%<br>92.0%<br>92.5%<br>91.5%<br>90.5% | -<br>-<br>-<br>-<br>-<br>-<br>-<br>- | Measured at full load and steady-state temperature in 25°C ambient; (Efficiency will be about 2.0% lower if measured immediately after startup.) |
| MTBF   | -  | 339,000 Hours  | -                                    | Measured at 220Vac input, 80%Load and 25°C ambient temperature (MIL-HDBK-217F)   |
| Lifetime   | -  | 98,000 Hours   | -                                    | Measured at 220Vac input, 80%Load and 70°C case temperature; See lifetime vs. T <sub>c</sub> curve for the details                               |
| Operating Case Temperature for Safety T <sub>c_s</sub>   | -40°C  | -  | +90°C                                |  |
| Operating Case Temperature for Warranty T <sub>c_w</sub>   | -40°C  | -  | +75°C                                | Case temperature for 7 years warranty. <i>Please see Inventronics Warranty Statement for complete details.</i>                                   |
| Storage Temperature  | -40°C  | -  | +85°C                                | Humidity: 5%RH to 100%RH   |
| Dimensions<br>Inches (L × W × H)<br>Millimeters (L × W × H)  | 6.85 × 2.66 × 1.44<br>174 × 67.5 × 36.5                              |  |                                      | With mounting ear<br>7.92 × 2.66 × 1.44<br>201 × 67.5 × 36.5   |
| Net Weight   | -  | 890 g  | -                                    |  |

**Note:** All specifications are typical at 25°C unless otherwise stated.

## Dimming Specifications

| Parameter                                    |  | Min.                           | Typ.   | Max.             | Notes   |
|--|--|--------------------------------|--------|------------------|---|
| Absolute Maximum Voltage on the Vdim (+) Pin |  | -20 V                          | -      | 20 V             |   |
| Source Current on Vdim (+)Pin                |  | 200 uA                         | 300 uA | 450 uA           | Vdim(+) = 0 V   |
| Dimming Output Range                         | EUG-096S070DV<br>EUG-096S105DV<br>EUG-096S210DV<br>EUG-096S350DV | 10%I <sub>set</sub>            | -      | I <sub>set</sub> | 450mA ≤ I <sub>set</sub> ≤ 700mA<br>700mA ≤ I <sub>set</sub> ≤ 1050mA<br>1400mA ≤ I <sub>set</sub> ≤ 2100mA<br>2450mA ≤ I <sub>set</sub> ≤ 3500mA |
|  | EUG-096S070DV<br>EUG-096S105DV<br>EUG-096S210DV<br>EUG-096S350DV | 45mA<br>70mA<br>140mA<br>245mA | -      | I <sub>set</sub> | 45mA ≤ I <sub>set</sub> < 450mA<br>70mA ≤ I <sub>set</sub> < 700mA<br>140mA ≤ I <sub>set</sub> < 1400mA<br>245mA ≤ I <sub>set</sub> < 2450mA      |
| Recommended Dimming Range for 0-5V           |  | 0 V                            | -      | 5 V              | Dimming mode set to 0-5V in PC interface.   |
| Recommended Dimming Range for 0-10V          |  | 0 V                            | -      | 10 V             | Default 0-10V dimming mode with positive logic.   |
| PWM_in High Level                            |  | 3 V                            | -      | 10 V             | Dimming mode set to PWM in PC interface.  |
| PWM_in Low Level                             |  | -0.3 V                         | -      | 0.6 V            |   |
| PWM_in Frequency Range                       |  | 200 Hz                         | -      | 2 KHz            |   |
| PWM_in Duty Cycle                            |  | 1%                             | -      | 99%              |   |

**Note:** All specifications are typical at 25°C unless otherwise stated.

## Safety & EMC Compliance

| Safety Category         | Standard  |
|-------------------------|---|
| CE                      | EN 61347-1, EN61347-2-13  |
| KS                      | KS C 7655   |
| EMI Standards           | Notes   |
| EN 55015 <sup>(1)</sup> | Conducted emission Test & Radiated emission Test  |
| EN 61000-3-2            | Harmonic current emissions  |
| EN 61000-3-3            | Voltage fluctuations & flicker  |
| EMS Standards           | Notes   |
| EN 61000-4-2            | Electrostatic Discharge (ESD): 8 kV air discharge, 4 kV contact discharge                 |
| EN 61000-4-3            | Radio-Frequency Electromagnetic Field Susceptibility Test-RS                              |
| EN 61000-4-4            | Electrical Fast Transient / Burst-EFT   |
| EN 61000-4-5            | Surge Immunity Test: AC Power Line: line to line 6 kV, line to earth 10 kV <sup>(2)</sup> |
| EN 61000-4-6            | Conducted Radio Frequency Disturbances Test-CS  |
| EN 61000-4-8            | Power Frequency Magnetic Field Test   |

## Safety & EMC Compliance (Continued)

| Safety Category | Standard  |
|-----------------|---|
| EN 61000-4-11   | Voltage Dips  |
| EN 61547        | Electromagnetic Immunity Requirements Applies To Lighting Equipment |

- Note:** (1) This LED driver meets the EMI specifications above, but EMI performance of a luminaire that contains it depends also on the other devices connected to the driver and on the fixture itself.
- (2) To perform electric strength (hi-pot) testing, the “GDT ground disconnect” (nut and metal lock sheet) on the driver end-cap should be removed temporarily to prevent the internal gas discharge tube from conducting (as allowed by IEC 60598-1 Clause 10.2). After testing is completed, these items must be reinstalled to restore line-to-earth surge protection and secure the end cap.

## Lifetime vs. Case Temperature

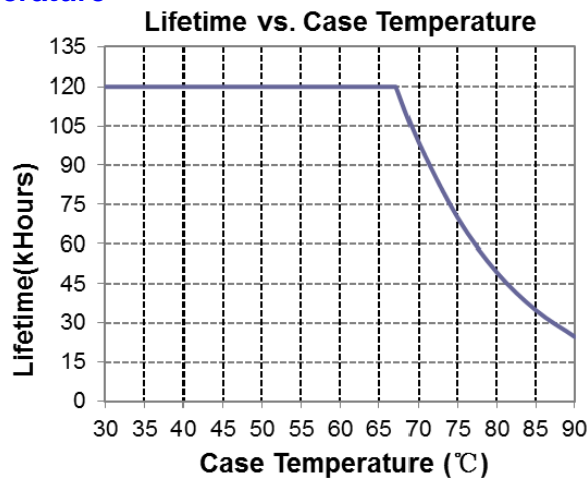

## Inrush Current Waveform

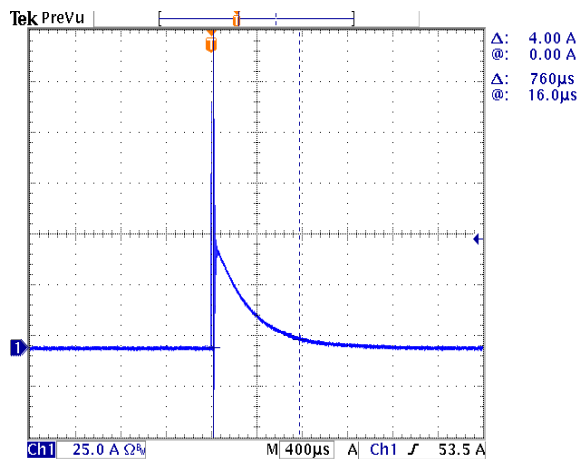

## Efficiency vs. Load

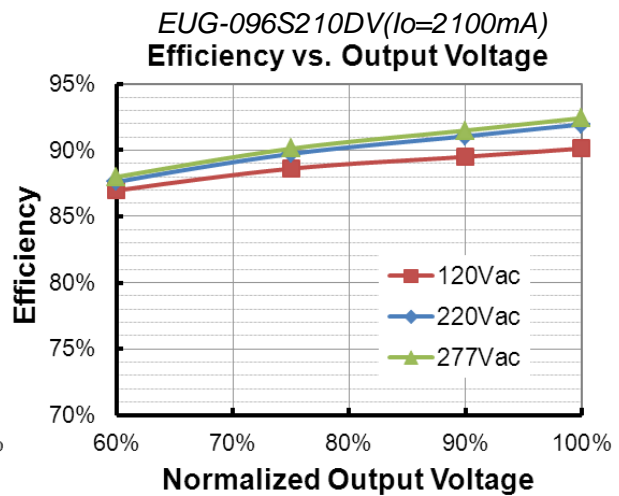
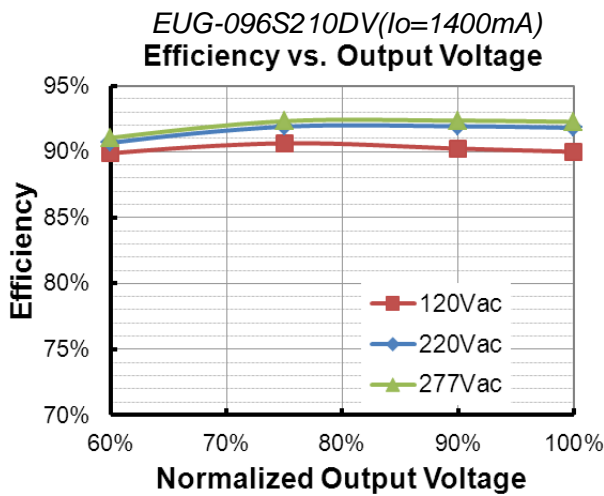
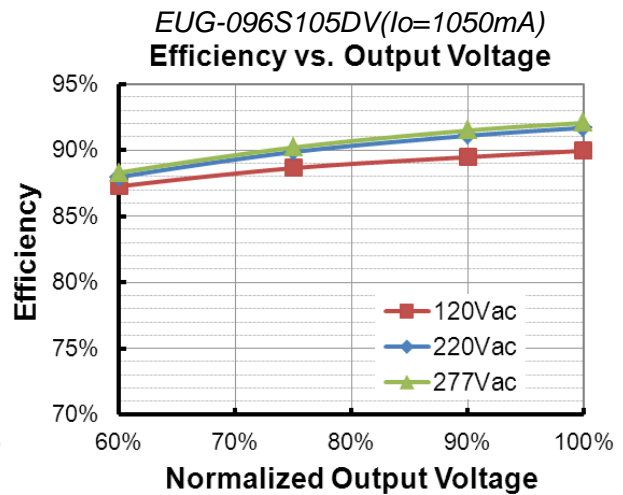
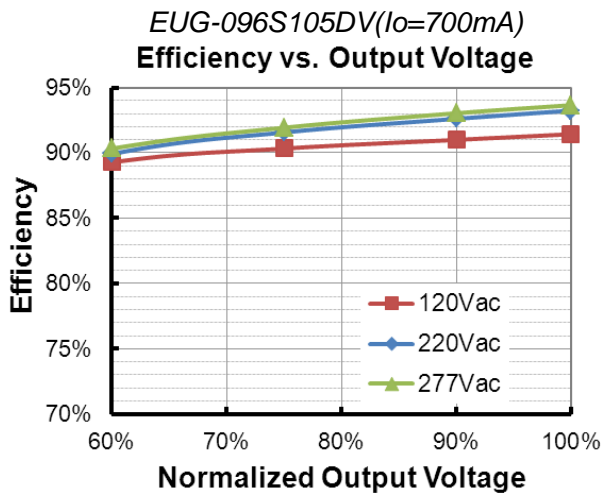
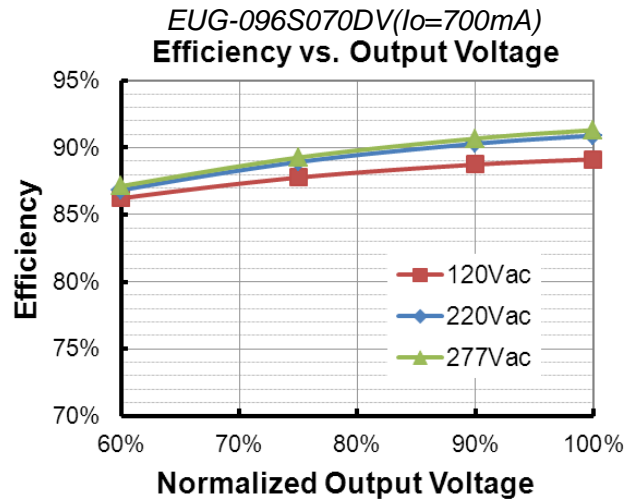
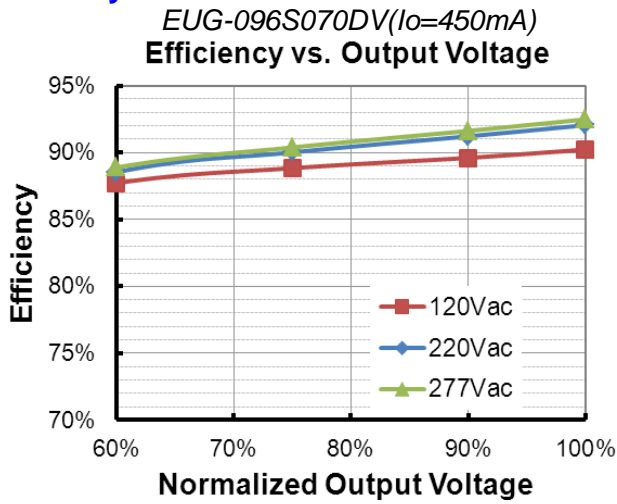

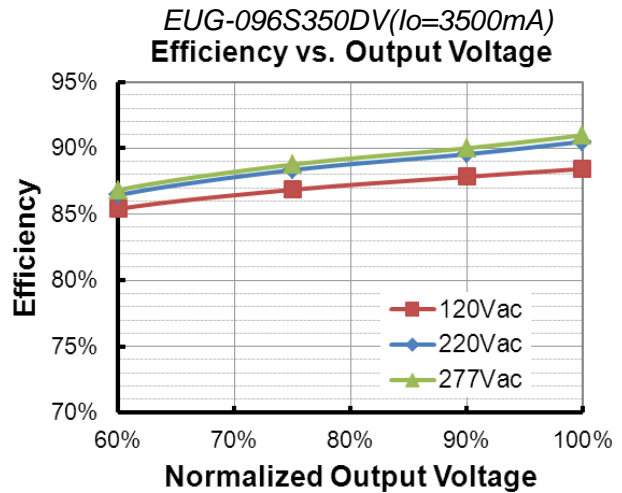
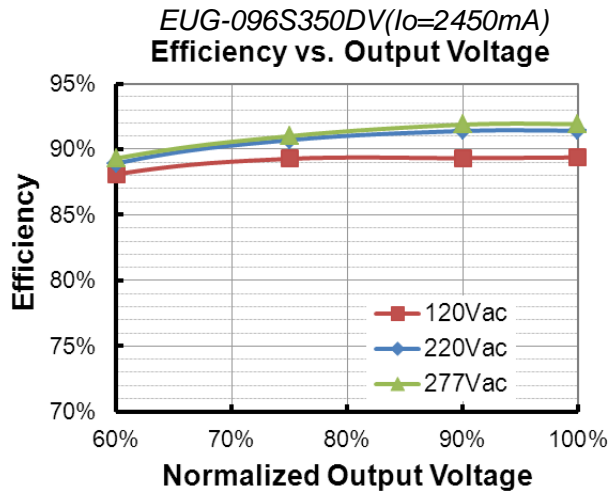

## Power Factor

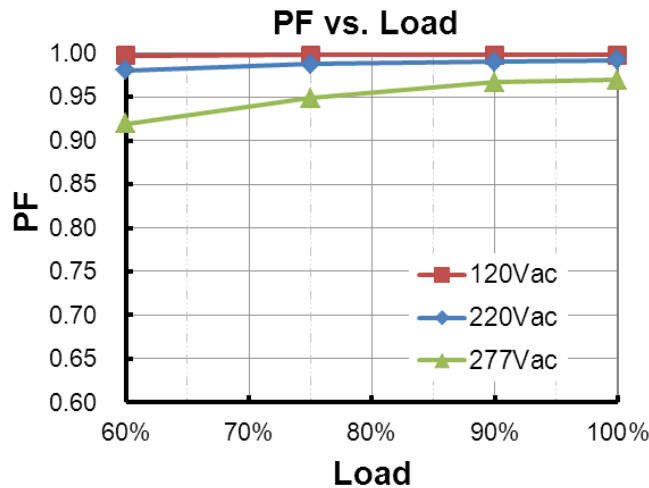

## Total Harmonic Distortion

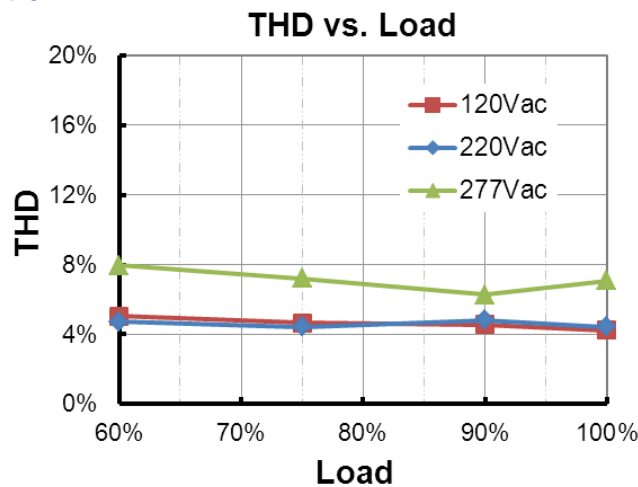



## Protection Functions

| Parameter                   | Notes  |
|-----------------------------|--|
| Over Temperature Protection | Decreases output current, returning to normal after over temperature is removed.   |
| Short Circuit Protection    | Auto Recovery. No damage will occur when any output is short circuited. The output shall return to normal when the fault condition is removed. |
| Over Voltage Protection     | Limits output voltage at no load and in case the normal voltage limit fails.   |

## Dimming

### ● 0-5V Dimming

The recommended implementation of the dimming control is provided below.

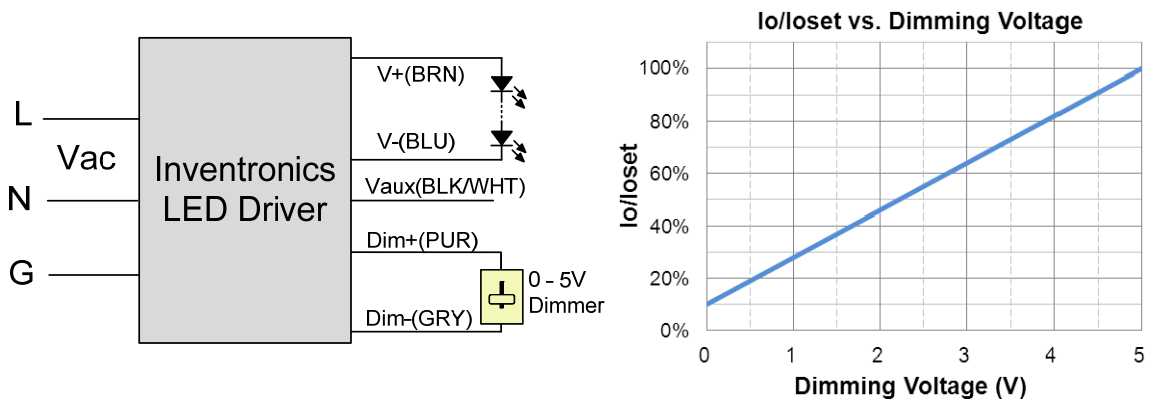

**Implementation 1: Positive logic**

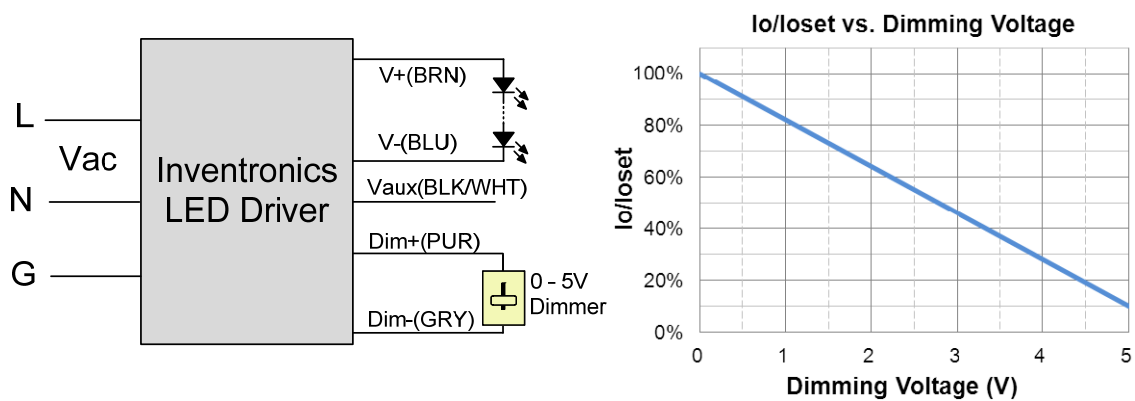

**Implementation 2: Negative logic**

### Notes:

1. The dimmer can also be replaced by an active 0-5V voltage source signal or passive components like resistors and zener.
2. Do NOT connect Dim- to the output V- or V+, otherwise the driver will not work properly.
3. If 0-5V dimming is not used, Dim + should be open.
4. When 0-5V negative logic dimming mode and Dim+ is open, the driver will output maximum current.

## ● 0-10V Dimming

The recommended implementation of the dimming control is provided below.

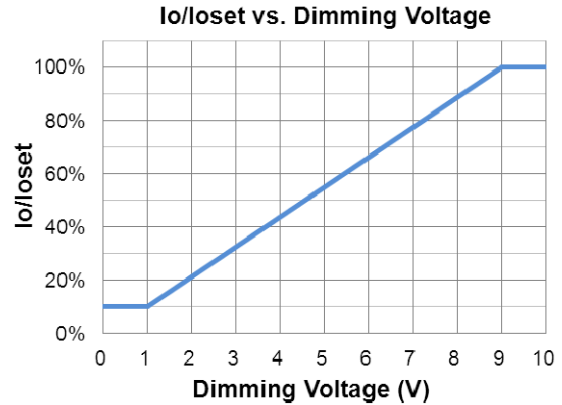
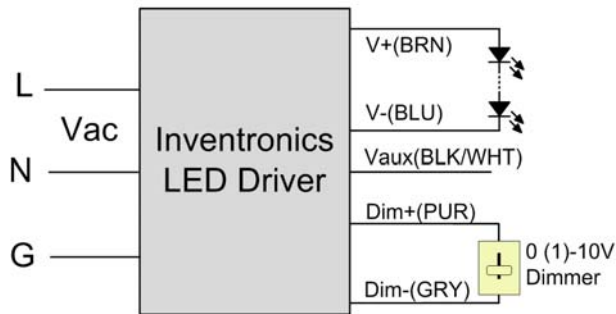

**Implementation 3: Positive logic**

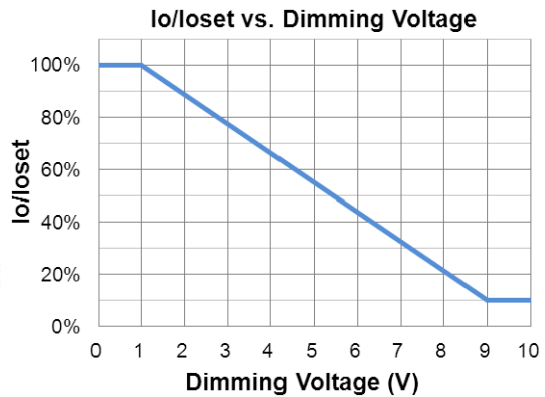
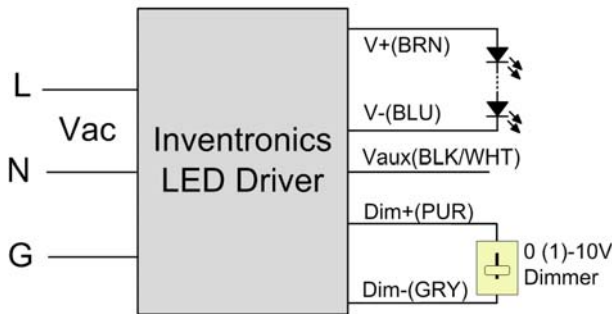

**Implementation 4: Negative logic**

### Notes:

1. The dimmer can also be replaced by an active 0-10V voltage source signal or passive components like resistors and zener.
2. Do NOT connect Dim- to the output V- or V+, otherwise the driver will not work properly.
3. If 0-10V dimming is not used, Dim + should be open.
4. When 0-10V negative logic dimming mode and Dim+ is open, the driver will output minimum current.

## ● PWM Dimming

The recommended implementation of the dimming control is provided below.

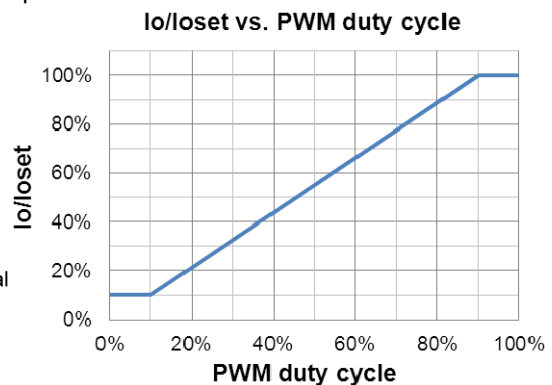
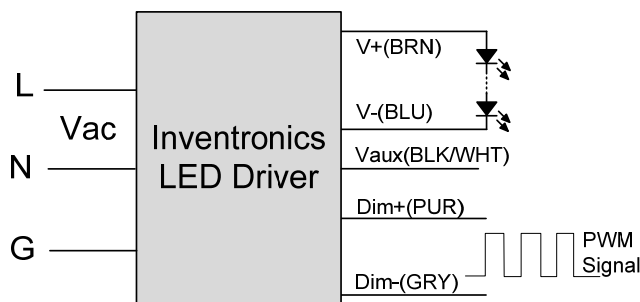

**Implementation 5: Positive logic**

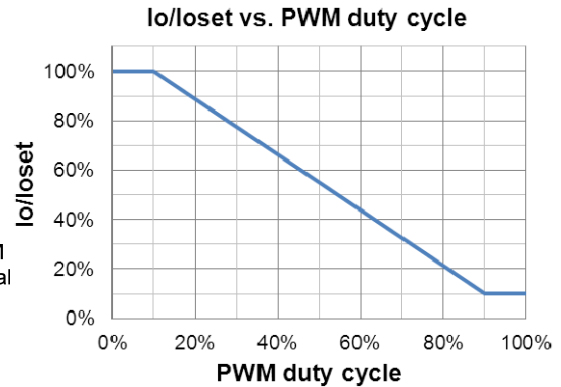
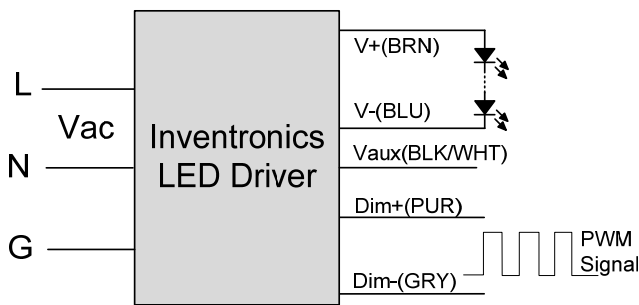

### Implementation 6: Negative logic

**Notes:**

1. Do NOT connect Dim- to the output V- or V+, otherwise the driver will not work properly.
2. If PWM dimming is not used, Dim + should be open.
3. When PWM negative logic dimming mode and Dim+ is open, the driver will output minimum current.

### ● Time Dimming

The software interface includes the following components:

- Light Level Configuration:** Five levels (1-5) and a final level, each with sliders for Dimming (e.g., 100%, 50%, 90%), Holding Time (e.g., 7H0M, 3H15M, 0H0M, 0H0M, 0H0M), and Fading Time (e.g., 0H45M, 0H40M, 0H0M, 0H0M, 0H0M).
- Driver Output Operating Region Graph:** Shows Voltage (V) on the y-axis (0 to 162) and Current (A) on the x-axis (0 to 1.26). A blue curve indicates the operating region, with a red box highlighting a specific operating point.
- Dimming vs. Time Graph:** Shows Dimming (%) on the y-axis (0% to 100%) and Time (H) on the x-axis (0 to 19). A red step function shows the dimming levels over time.

Set the timing curve by pulling the sliders.

## Programming Connection Diagram

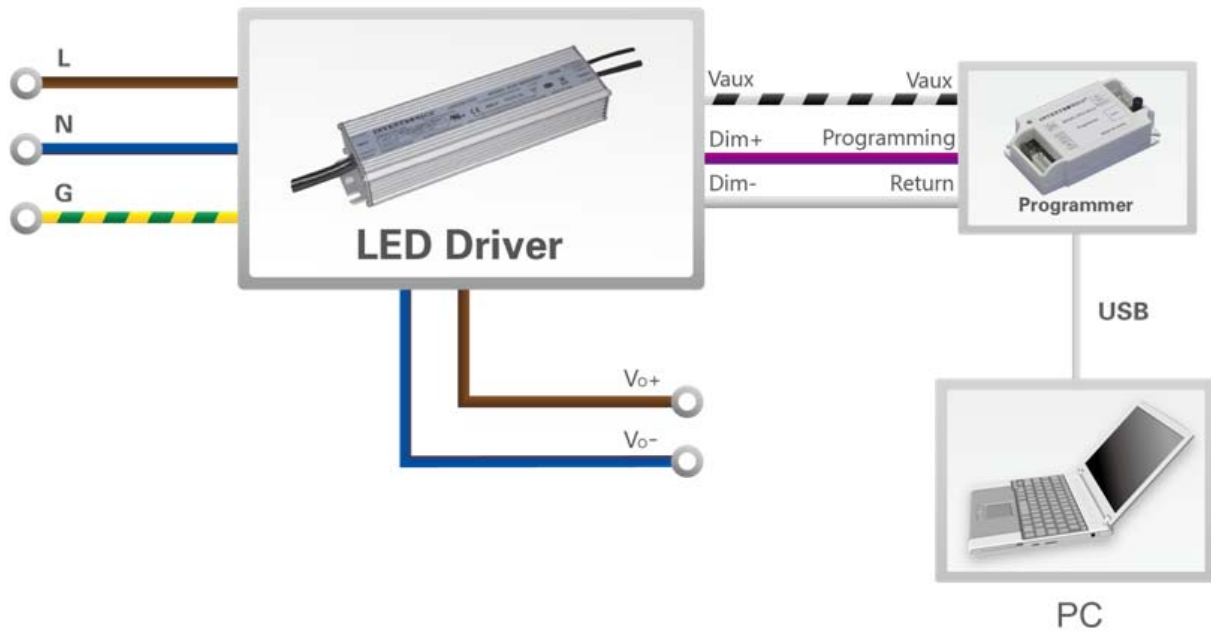

**Note:** The driver does not need to be powered on during the programming process.

- Please refer to [PRG-MUL2](#) (Programmer) datasheet for details.

## Mechanical Outline

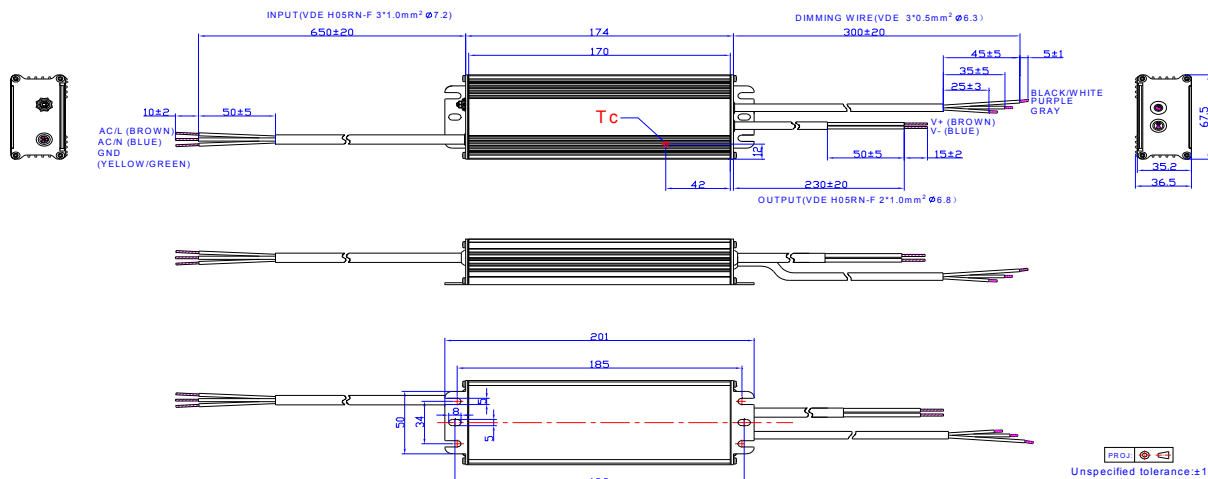

## RoHS Compliance

Our products comply with the European Directive 2011/65/EC, calling for the elimination of lead and other hazardous substances from electronic products.

## Revision History

| Change Date | Rev. | Description of Change                        |  |         |
|-------------|------|--|--|---------|
|             |      | Item   | From   | To      |
| 2015-07-08  | A    | Datasheets Release                           | /  | /       |
| 2016-02-29  | B    | TUV, BIS                                     | /  | Added   |
|             |      | EUG-096S070DV                                | /  | Added   |
|             |      | Net Weight                                   | /  | Updated |
|             |      | Safety & EMC Compliance                      | KS   | Added   |
|             |      | Mechanical Outline                           | /  | Updated |
| 2017-07-27  | C    | Models                                       | Notes  | Updated |
|             |      | Input Specifications                         | PF/THD                                       | Updated |
|             |      | Output Specifications                        | Temperature Coefficient of loset             | Updated |
|             |      | General Specifications                       | Dimensions                                   | Updated |
|             |      | Safety & EMC Compliance                      | /  | Updated |
|             |      | Mechanical Outline                           | /  | Updated |
| 2017-10-26  | D    | Features                                     | 7 Years Warranty                             | Added   |
|             |      | Operating Case Temperature for Warranty Tc_w | /  | Updated |
| 2018-01-31  | E    | Description                                  | /  | Updated |
|             |      | General Specifications                       | Lifetime                                     | Updated |
|             |      | General Specifications                       | Operating Case Temperature for Warranty Tc_w | Updated |
|             |      | Lifetime vs. Case Temperature                | /  | Updated |