

2x8 DC Module Y19

SMJD-4835016K-XXN1

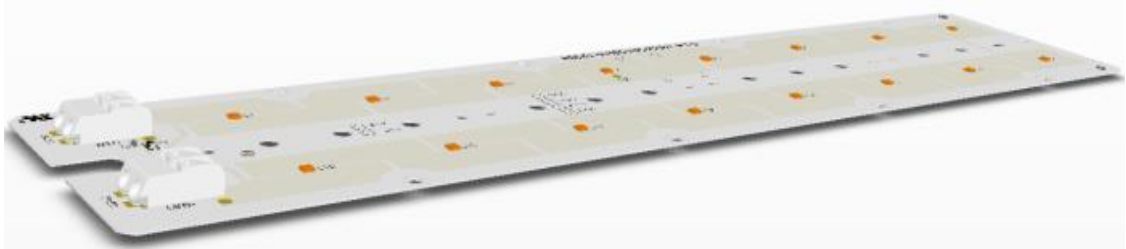

Product Brief

Description

- WICOP package on board with modular design that is extendable to multi applications
- Poke-in terminals for both input and thermal detection
- Thermal detection circuit on board and coming up with poke-in connector that enabled the module works steady and reliably
- Multi CCT with tight color consistency
- Equipped with multiple optics matching with various projects demanding
- Support dimming and smart control

Features and Benefits

- Long Life Time
- High Efficacy
- 4-step
- Lead Free Product
- RoHS Compliant

Key Applications

- Parking lighting
- Street lighting
- Area lighting
- Tunnel lighting

Table 1- Order Code

Nominal CCT (K)	CRI	Lens Type	Order Code
6500	70	-	SMJD-4835016K-XXN100E55A047ALL
5700	70	-	SMJD-4835016K-XXN100E55B047ALL
5000	70	-	SMJD-4835016K-XXN100E77C047ALL
4000	70	-	SMJD-4835016K-XXN100E77E047ALL
3000	70	-	SMJD-4835016K-XXN100E05G047ALL
2700	70	-	SMJD-4835016K-XXN100E05H047ALL
2200	70	-	SMJD-4835016K-XXN100D78K047ALL
2200	80	-	SMJD-4835016K-XXN100D11K048ALL

Table of Contents

Index	
• Product Brief	
• Table of Contents	
• Performance Characteristics	
• Absolute Maximum Ratings	
• Relative Spectral Distribution	
• Color Bin Structure	
• Mechanical Dimensions	
• Circuit Drawing	
• Application Guide	
• Product Nomenclature	
• Marking Information	
• Label Information	
• Packing Introduction	
• Precaution for Use	
• Storage before use	
• Guidelines for properly working with module	
• Company Information	
• Revision History	

Performance Characteristics

Table 2-1. Electro Optical Characteristics, $I_F = 0.7A$, $T_c = 85^\circ C$ [1]

Parameter	Symbol	Value			Unit	Mark
		Min.	Typ.	Max.		
Luminous Flux	Φ_V [2]	4440	4770	-	Lm	E77 (C,E Rank)
		4230	4550	-		E55 (A,B Rank)
		3770	4050	-		E05 (G,H Rank)
		3520	3780	-		D78 (K Rank)
Luminous Efficiency	LPW	-	142	-	Lm/W	C,E Rank
		-	135	-		A,B Rank
		-	121	-		G,H Rank
		-	113	-		K Rank
Correlated Color Temperature [3]	CCT	2100	2200	2300	K	K04
		2600	2700	2900		H04
		2900	3000	3200		G04
		3700	4000	4200		E04
		4700	5000	5300		C04
		5300	5700	6000		B04
		6000	6500	7000		A04
Color Consistency		-	-	4	SDCM	
CRI	Ra	70	-	-	-	
Forward Voltage	V_{in}	44	48	52	Vdc	D48
Input Current	I_F	-	0.7	-	A	-
Power Consumption	P		33.6		W	33.6W
Viewing Angle	$2\theta_{1/2}$		140		deg.	

Notes :

- (1) The above data were tested at $T_c = 85^\circ C$.
- (2) Φ_V is the total luminous flux output measured with an integrated sphere, the tolerance is 7% .
- (3) Correlated Color Temperature is derived from the CIE 1931 Chromaticity diagram.
- (4) To use the module properly, recommend to drive the module by a Constant Current Source (CCS). But the Maximum output voltage of the CCS should be limited by referring this datasheet.

Performance Characteristics

Table 2-2. Electro Optical Characteristics, $I_F=0.7A$, $T_c=85^\circ C$ [1]

Parameter	Symbol	Value			Unit	Mark
		Min.	Typ.	Max.		
Luminous Flux	Φ_V [2]	2890	3110	-	Lm	D11 (K Rank)
Luminous Efficiency	LPW	-	92.5	-	Lm/W	K Rank
Correlated Color Temperature [3]	CCT	2100	2200	2300	K	K04
Color Consistency		-	-	4	SDCM	
CRI	Ra	80	-	-	-	
Forward Voltage	V_{in}	44	48	52	Vdc	D48
Input Current	I_F	-	0.7	-	A	-
Power Consumption	P		33.6		W	33.6W
Viewing Angle	$2\Theta_{1/2}$		140		deg.	

Notes :

- (1) The above data were tested at $T_c=85^\circ C$.
- (2) Φ_V is the total luminous flux output measured with an integrated sphere, the tolerance is 7% .
- (3) Correlated Color Temperature is derived from the CIE 1931 Chromaticity diagram.
- (4) To use the module properly, recommend to drive the module by a Constant Current Source (CCS). But the Maximum output voltage of the CCS should be limited by referring this datasheet.

Absolute Maximum Ratings

Table 3. Absolute Maximum Ratings, $I_F=0.7A$, $T_c= 85^\circ C$ ⁽¹⁾

Parameter	Symbol	Unit	Value	Remark
Power Consumption	P	W	39	$P_{Typ.} = 33.6W$
Driving Current ⁽²⁾	I_F	A	0.8	$I_{F_Typ.} = 0.7A$
Operating Temperature ⁽³⁾	T_c	$^\circ C$	- 40 ~ 105	Reference point
Storage Temperature	T_{stg}	$^\circ C$	- 40 ~ 105	With no power
ESD Sensitivity	-	KV	± 15	IEC Air
			± 8	HBM

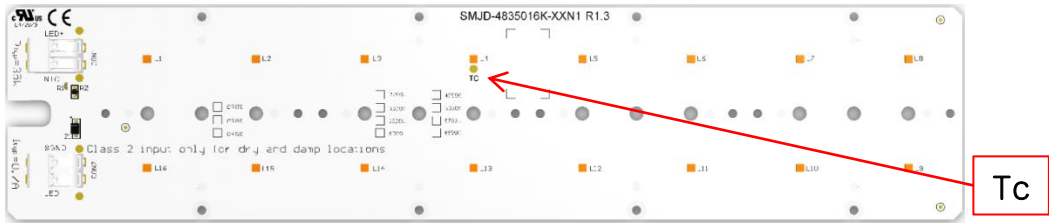
ILLUSTRATION 1: How to predict components temperature ⁽⁴⁾

Notes :

- (1) All guarantee are based on the Absolute Maximum Ratings listed.
- (2) Please use a Constant Current Source (CCS) to drive the module, the typical V_F of module is around 48VDC and V_{F_MAX} is around 52VDC, respectively.
- (3) Operating temperature was tested at the assigned T_c point on the PCB.
- (4) To ensure the module works properly, DO NOT let the T_c upper than 105 $^\circ C$;

Relative Spectral Distribution

Fig 1. Relative Spectral Distribution vs. Wavelength Characteristic

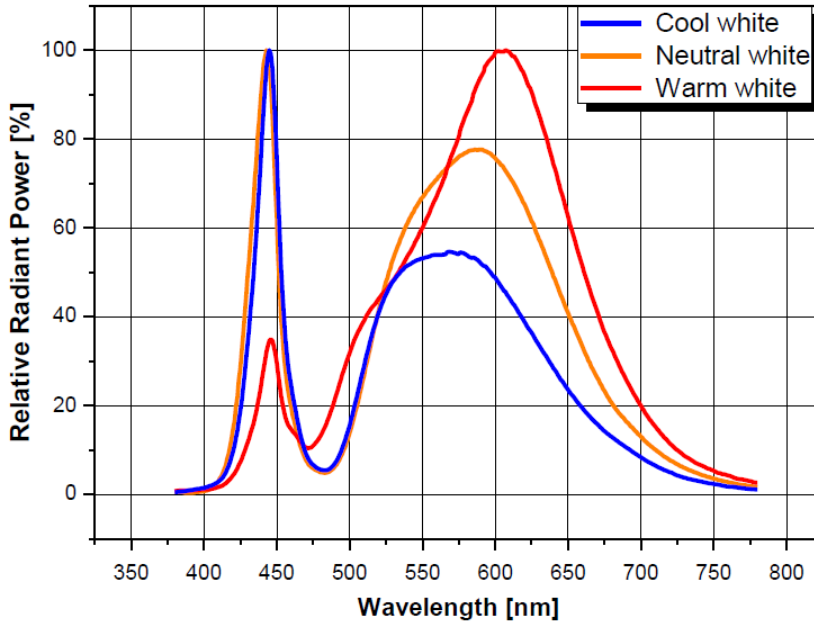
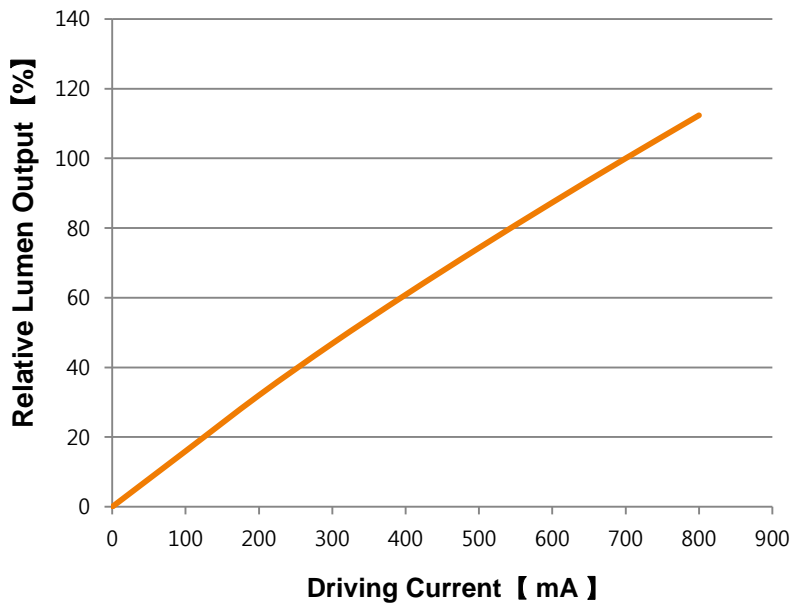
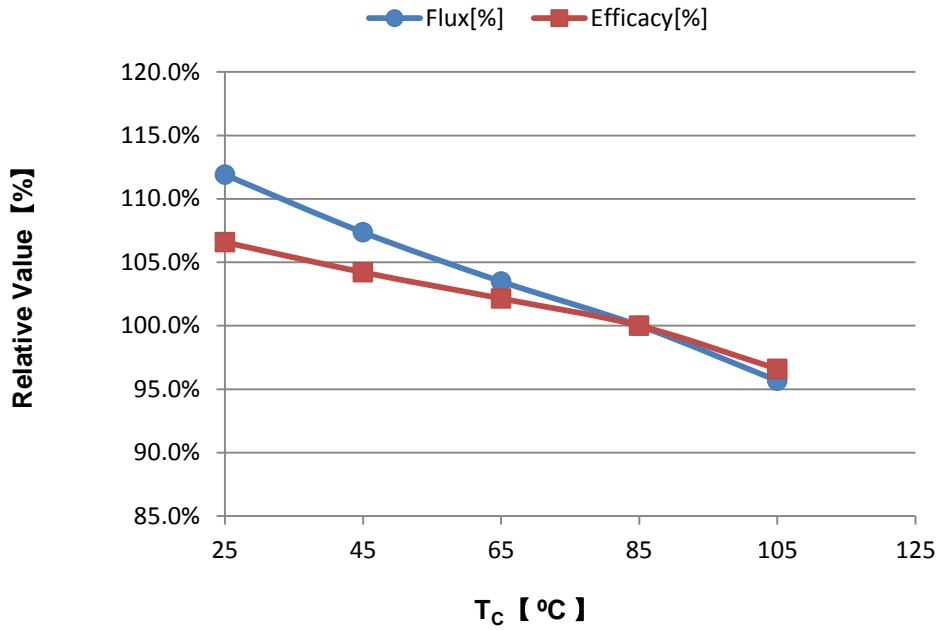

Fig 2. Forward Current vs. Relative Luminous Flux, $T_c=85^\circ\text{C}$



Relative Spectral Distribution

Fig 3. Flux and Efficacy Versus Temperature at T_c (at I_F nominal)



T_c [°C]	Flux[%]	Efficacy[%]
25	111.9	106.6
45	107.4	104.2
65	103.5	102.1
85	100	100
105	95.7	96.6

Relative Spectral Distribution

Fig 4. Typical Spatial Distribution

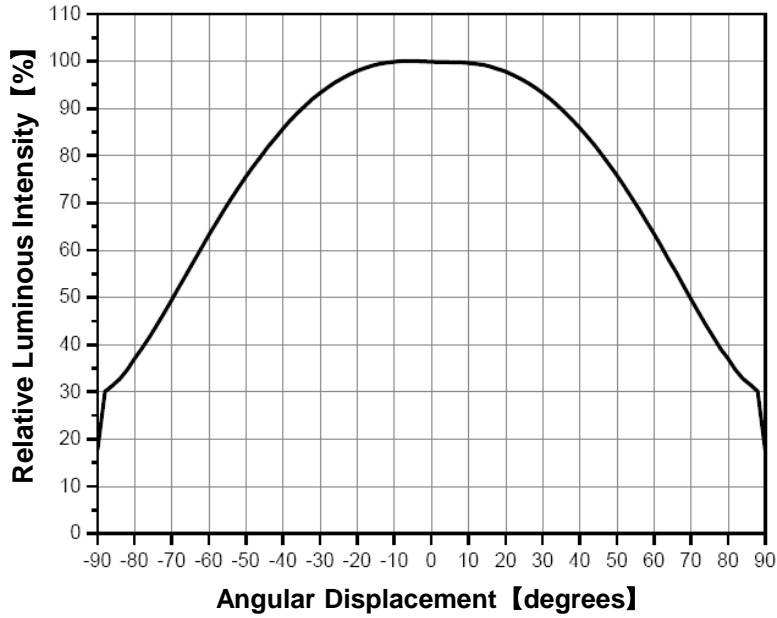

Color Bin Structure

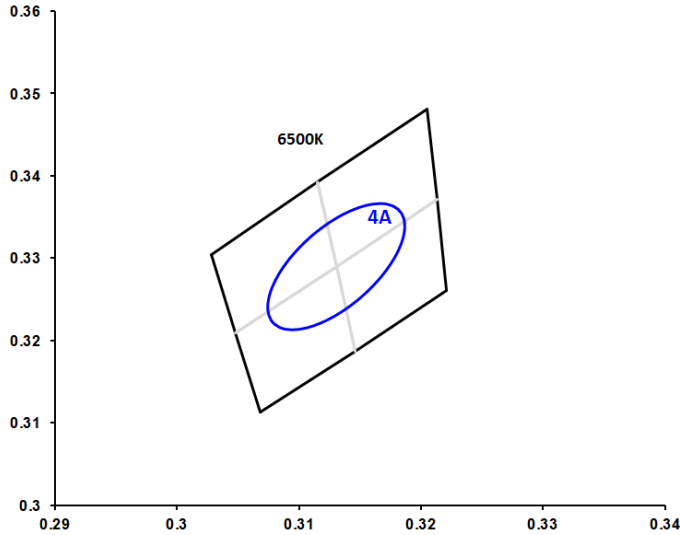
Fig 5. CIE Chromaticity Diagram

6500K 4Step

4A							
CIE X	CIE Y	CIE X	CIE Y	CIE X	CIE Y	CIE X	CIE Y
0.3174	0.3290	0.3131	0.3349	0.3087	0.3290	0.3131	0.3231
0.3175	0.3293	0.3127	0.3345	0.3086	0.3287	0.3134	0.3234
0.3176	0.3296	0.3124	0.3342	0.3085	0.3284	0.3137	0.3237
0.3178	0.3299	0.3121	0.3339	0.3083	0.3281	0.3140	0.3240
0.3179	0.3302	0.3118	0.3337	0.3082	0.3277	0.3143	0.3243
0.3180	0.3306	0.3116	0.3334	0.3081	0.3274	0.3145	0.3245
0.3182	0.3310	0.3114	0.3332	0.3079	0.3270	0.3147	0.3248
0.3183	0.3314	0.3112	0.3329	0.3078	0.3265	0.3149	0.3250
0.3184	0.3319	0.3110	0.3327	0.3077	0.3260	0.3151	0.3253
0.3185	0.3324	0.3108	0.3325	0.3076	0.3255	0.3153	0.3255
0.3186	0.3330	0.3107	0.3322	0.3075	0.3249	0.3154	0.3257
0.3187	0.3336	0.3105	0.3320	0.3074	0.3243	0.3156	0.3259
0.3187	0.3342	0.3104	0.3318	0.3074	0.3237	0.3157	0.3261
0.3186	0.3349	0.3102	0.3316	0.3075	0.3231	0.3159	0.3263
0.3184	0.3354	0.3101	0.3314	0.3077	0.3225	0.3160	0.3265
0.3181	0.3359	0.3100	0.3312	0.3080	0.3220	0.3161	0.3267
0.3177	0.3363	0.3098	0.3310	0.3084	0.3216	0.3163	0.3269
0.3172	0.3366	0.3097	0.3308	0.3089	0.3214	0.3164	0.3271
0.3167	0.3366	0.3096	0.3306	0.3094	0.3213	0.3165	0.3274
0.3161	0.3366	0.3095	0.3304	0.3100	0.3214	0.3166	0.3276
0.3155	0.3364	0.3094	0.3302	0.3106	0.3215	0.3167	0.3278
0.3149	0.3361	0.3092	0.3300	0.3112	0.3218	0.3169	0.3280
0.3144	0.3358	0.3091	0.3297	0.3117	0.3221	0.3170	0.3282
0.3139	0.3355	0.3090	0.3295	0.3122	0.3224	0.3171	0.3285
0.3134	0.3352	0.3089	0.3292	0.3127	0.3228	0.3172	0.3287

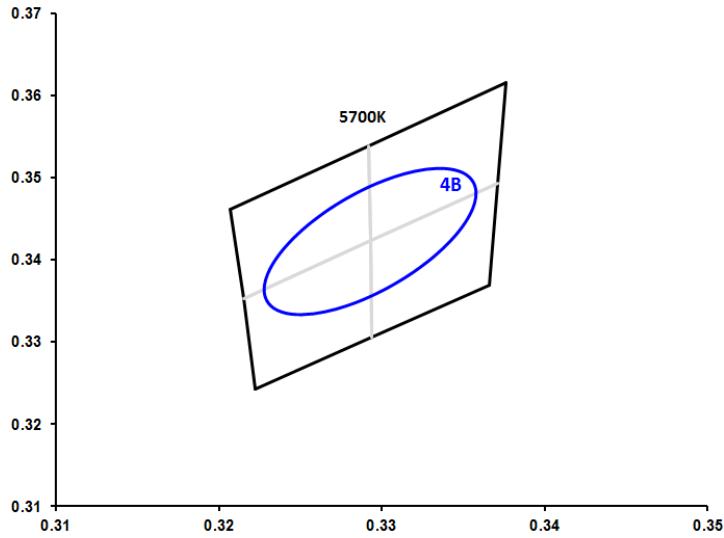
Color Bin Structure

Fig 6. CIE Chromaticity Diagram

5700K 4Step

4B							
CIE X	CIE Y	CIE X	CIE Y	CIE X	CIE Y	CIE X	CIE Y
0.3342	0.3422	0.3293	0.3490	0.3244	0.3422	0.3293	0.3355
0.3343	0.3426	0.3289	0.3486	0.3242	0.3419	0.3297	0.3359
0.3345	0.3429	0.3285	0.3482	0.3241	0.3416	0.3300	0.3363
0.3346	0.3433	0.3282	0.3479	0.3239	0.3412	0.3304	0.3366
0.3348	0.3437	0.3279	0.3476	0.3238	0.3408	0.3306	0.3369
0.3350	0.3441	0.3276	0.3473	0.3236	0.3404	0.3309	0.3372
0.3351	0.3446	0.3274	0.3470	0.3234	0.3399	0.3311	0.3375
0.3353	0.3451	0.3272	0.3467	0.3233	0.3394	0.3314	0.3378
0.3354	0.3456	0.3270	0.3464	0.3231	0.3389	0.3316	0.3381
0.3356	0.3462	0.3268	0.3462	0.3230	0.3383	0.3318	0.3383
0.3357	0.3469	0.3266	0.3459	0.3229	0.3376	0.3320	0.3386
0.3358	0.3476	0.3264	0.3457	0.3228	0.3369	0.3321	0.3388
0.3358	0.3484	0.3263	0.3455	0.3228	0.3361	0.3323	0.3390
0.3357	0.3491	0.3261	0.3452	0.3229	0.3354	0.3325	0.3393
0.3355	0.3498	0.3259	0.3450	0.3230	0.3347	0.3326	0.3395
0.3352	0.3504	0.3258	0.3448	0.3234	0.3341	0.3328	0.3397
0.3347	0.3508	0.3256	0.3446	0.3238	0.3337	0.3329	0.3399
0.3341	0.3511	0.3255	0.3443	0.3244	0.3334	0.3330	0.3402
0.3335	0.3511	0.3254	0.3441	0.3251	0.3334	0.3332	0.3404
0.3328	0.3510	0.3252	0.3439	0.3258	0.3335	0.3333	0.3406
0.3321	0.3508	0.3251	0.3436	0.3265	0.3337	0.3335	0.3409
0.3314	0.3505	0.3249	0.3434	0.3272	0.3340	0.3336	0.3411
0.3308	0.3501	0.3248	0.3431	0.3278	0.3344	0.3337	0.3414
0.3302	0.3497	0.3247	0.3428	0.3283	0.3348	0.3339	0.3417
0.3297	0.3493	0.3245	0.3425	0.3288	0.3352	0.3340	0.3420

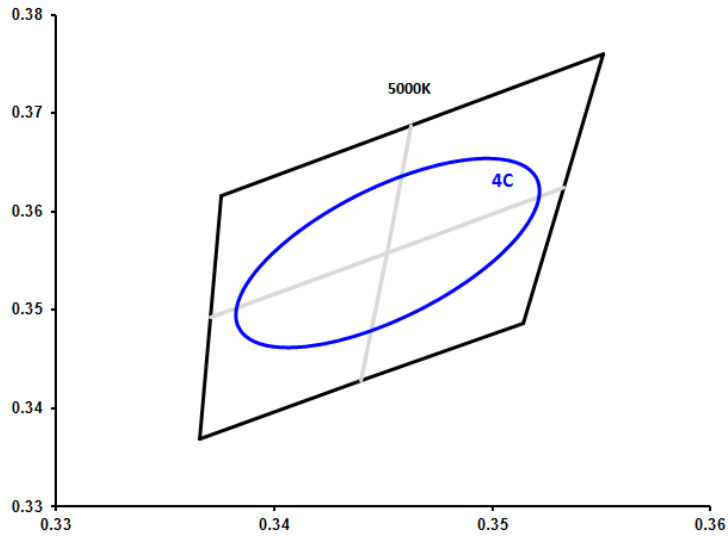
Color Bin Structure

Fig 7. CIE Chromaticity Diagram

5000K 4Step

4C							
CIE X	CIE Y	CIE X	CIE Y	CIE X	CIE Y	CIE X	CIE Y
0.3505	0.3558	0.3452	0.3631	0.3399	0.3558	0.3452	0.3485
0.3506	0.3561	0.3448	0.3627	0.3398	0.3555	0.3456	0.3489
0.3508	0.3565	0.3444	0.3623	0.3396	0.3551	0.3460	0.3493
0.3509	0.3569	0.3440	0.3619	0.3395	0.3547	0.3464	0.3497
0.3511	0.3573	0.3437	0.3616	0.3393	0.3543	0.3467	0.3500
0.3513	0.3578	0.3434	0.3612	0.3391	0.3538	0.3470	0.3504
0.3515	0.3583	0.3432	0.3609	0.3389	0.3533	0.3472	0.3507
0.3516	0.3588	0.3429	0.3606	0.3388	0.3528	0.3475	0.3510
0.3518	0.3594	0.3427	0.3603	0.3386	0.3522	0.3477	0.3513
0.3519	0.3601	0.3425	0.3600	0.3385	0.3515	0.3479	0.3516
0.3521	0.3608	0.3423	0.3598	0.3383	0.3508	0.3481	0.3518
0.3521	0.3615	0.3421	0.3595	0.3383	0.3501	0.3483	0.3521
0.3522	0.3623	0.3419	0.3593	0.3382	0.3493	0.3485	0.3523
0.3521	0.3631	0.3418	0.3590	0.3383	0.3485	0.3486	0.3526
0.3519	0.3639	0.3416	0.3588	0.3385	0.3477	0.3488	0.3528
0.3515	0.3645	0.3415	0.3585	0.3389	0.3471	0.3489	0.3531
0.3511	0.3650	0.3413	0.3583	0.3393	0.3466	0.3491	0.3533
0.3504	0.3653	0.3411	0.3580	0.3400	0.3463	0.3493	0.3536
0.3497	0.3654	0.3410	0.3578	0.3407	0.3462	0.3494	0.3538
0.3490	0.3653	0.3408	0.3575	0.3414	0.3463	0.3496	0.3541
0.3482	0.3651	0.3407	0.3573	0.3422	0.3465	0.3497	0.3543
0.3475	0.3647	0.3406	0.3570	0.3429	0.3469	0.3498	0.3546
0.3468	0.3643	0.3404	0.3567	0.3436	0.3473	0.3500	0.3549
0.3462	0.3639	0.3403	0.3564	0.3442	0.3477	0.3501	0.3552
0.3457	0.3635	0.3401	0.3561	0.3447	0.3481	0.3503	0.3555

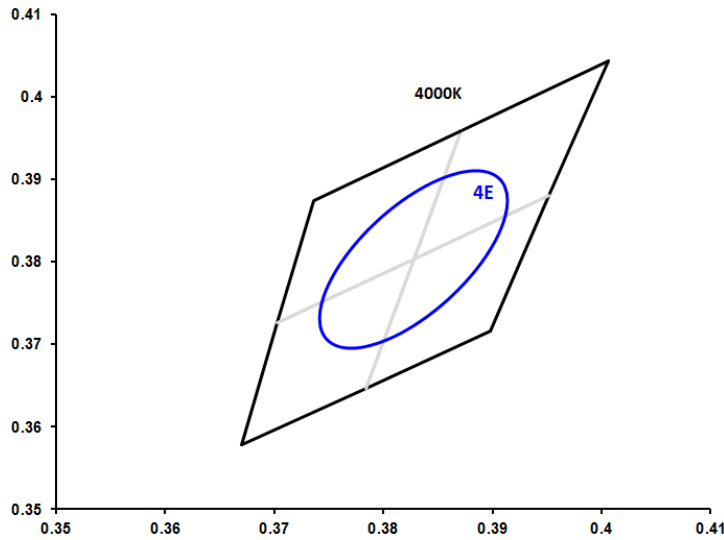
Color Bin Structure

Fig 8. CIE Chromaticity Diagram

4000K 4Step

4E							
CIE X	CIE Y	CIE X	CIE Y	CIE X	CIE Y	CIE X	CIE Y
0.3892	0.3803	0.3827	0.3883	0.3763	0.3803	0.3827	0.3723
0.3894	0.3807	0.3823	0.3879	0.3761	0.3799	0.3832	0.3727
0.3896	0.3812	0.3818	0.3875	0.3759	0.3794	0.3837	0.3731
0.3899	0.3817	0.3814	0.3872	0.3756	0.3789	0.3841	0.3734
0.3901	0.3822	0.3811	0.3868	0.3754	0.3784	0.3844	0.3738
0.3903	0.3828	0.3807	0.3865	0.3752	0.3778	0.3848	0.3741
0.3906	0.3834	0.3804	0.3861	0.3749	0.3772	0.3851	0.3745
0.3908	0.3841	0.3802	0.3858	0.3747	0.3765	0.3853	0.3748
0.3910	0.3848	0.3799	0.3855	0.3745	0.3758	0.3856	0.3751
0.3912	0.3856	0.3796	0.3852	0.3743	0.3750	0.3859	0.3754
0.3913	0.3865	0.3794	0.3849	0.3742	0.3741	0.3861	0.3757
0.3914	0.3874	0.3792	0.3846	0.3741	0.3732	0.3863	0.3760
0.3913	0.3883	0.3789	0.3844	0.3742	0.3723	0.3866	0.3762
0.3911	0.3892	0.3787	0.3841	0.3744	0.3714	0.3868	0.3765
0.3907	0.3899	0.3785	0.3838	0.3748	0.3707	0.3870	0.3768
0.3902	0.3905	0.3783	0.3835	0.3753	0.3701	0.3872	0.3771
0.3895	0.3909	0.3781	0.3832	0.3760	0.3697	0.3874	0.3774
0.3887	0.3911	0.3779	0.3830	0.3768	0.3695	0.3876	0.3776
0.3878	0.3910	0.3777	0.3827	0.3777	0.3696	0.3878	0.3779
0.3869	0.3908	0.3775	0.3824	0.3786	0.3698	0.3880	0.3782
0.3861	0.3905	0.3773	0.3821	0.3794	0.3701	0.3882	0.3785
0.3853	0.3901	0.3771	0.3817	0.3802	0.3705	0.3884	0.3789
0.3845	0.3896	0.3769	0.3814	0.3810	0.3710	0.3886	0.3792
0.3839	0.3892	0.3767	0.3811	0.3816	0.3714	0.3888	0.3795
0.3833	0.3888	0.3765	0.3807	0.3822	0.3718	0.3890	0.3799

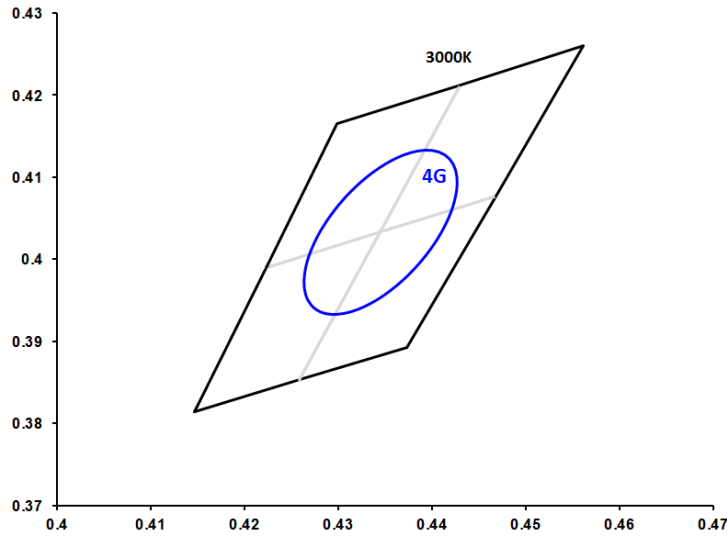
Color Bin Structure

Fig 9. CIE Chromaticity Diagram

3000K 4Step

4G							
CIE X	CIE Y	CIE X	CIE Y	CIE X	CIE Y	CIE X	CIE Y
0.4410	0.4033	0.4345	0.4113	0.4280	0.4033	0.4345	0.3953
0.4412	0.4037	0.4340	0.4109	0.4278	0.4029	0.4350	0.3957
0.4414	0.4042	0.4336	0.4105	0.4276	0.4024	0.4354	0.3961
0.4416	0.4047	0.4332	0.4102	0.4274	0.4019	0.4358	0.3964
0.4418	0.4052	0.4328	0.4098	0.4272	0.4014	0.4362	0.3968
0.4420	0.4057	0.4325	0.4095	0.4270	0.4009	0.4365	0.3971
0.4422	0.4063	0.4322	0.4092	0.4268	0.4003	0.4369	0.3974
0.4424	0.4070	0.4319	0.4089	0.4267	0.3996	0.4371	0.3977
0.4425	0.4077	0.4316	0.4086	0.4265	0.3989	0.4374	0.3980
0.4426	0.4085	0.4314	0.4083	0.4264	0.3981	0.4377	0.3983
0.4427	0.4092	0.4311	0.4080	0.4264	0.3974	0.4379	0.3986
0.4427	0.4100	0.4309	0.4077	0.4264	0.3966	0.4382	0.3989
0.4425	0.4108	0.4307	0.4074	0.4265	0.3958	0.4384	0.3992
0.4423	0.4116	0.4304	0.4071	0.4268	0.3950	0.4386	0.3995
0.4419	0.4122	0.4302	0.4069	0.4272	0.3944	0.4388	0.3997
0.4414	0.4127	0.4300	0.4066	0.4277	0.3939	0.4390	0.4000
0.4407	0.4131	0.4298	0.4063	0.4283	0.3935	0.4392	0.4003
0.4400	0.4133	0.4296	0.4060	0.4290	0.3933	0.4394	0.4006
0.4392	0.4133	0.4294	0.4057	0.4298	0.3933	0.4396	0.4009
0.4384	0.4132	0.4292	0.4054	0.4306	0.3934	0.4398	0.4012
0.4377	0.4130	0.4290	0.4051	0.4314	0.3936	0.4400	0.4015
0.4369	0.4127	0.4288	0.4048	0.4321	0.3939	0.4402	0.4018
0.4363	0.4124	0.4286	0.4044	0.4328	0.3942	0.4404	0.4022
0.4356	0.4120	0.4284	0.4041	0.4334	0.3946	0.4406	0.4025
0.4350	0.4116	0.4282	0.4037	0.4340	0.3950	0.4408	0.4029

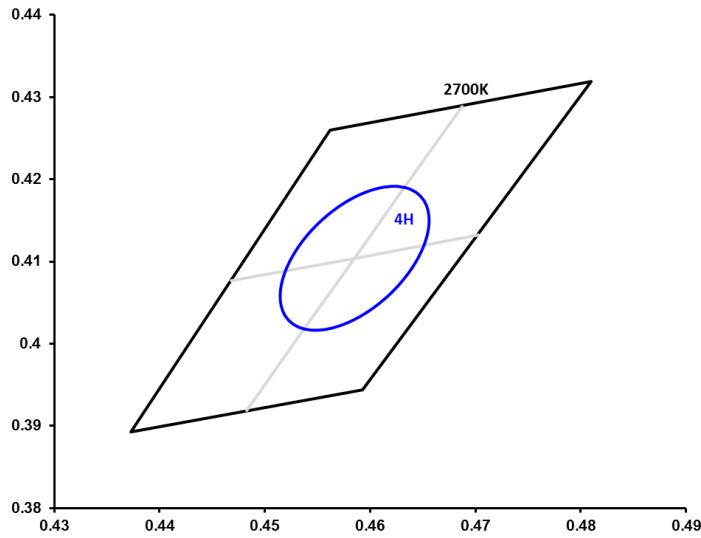
Color Bin Structure

Fig 10. CIE Chromaticity Diagram

2700K 4Step

4H							
CIE X	CIE Y	CIE X	CIE Y	CIE X	CIE Y	CIE X	CIE Y
0.4645	0.4104	0.4585	0.4178	0.4525	0.4104	0.4585	0.4030
0.4647	0.4108	0.4581	0.4175	0.4524	0.4100	0.4590	0.4033
0.4648	0.4112	0.4577	0.4172	0.4522	0.4096	0.4594	0.4036
0.4650	0.4116	0.4573	0.4169	0.4521	0.4092	0.4598	0.4039
0.4651	0.4121	0.4569	0.4166	0.4519	0.4087	0.4601	0.4042
0.4653	0.4126	0.4566	0.4163	0.4518	0.4082	0.4604	0.4045
0.4654	0.4131	0.4563	0.4160	0.4517	0.4077	0.4607	0.4048
0.4655	0.4137	0.4560	0.4157	0.4516	0.4071	0.4610	0.4051
0.4656	0.4143	0.4558	0.4154	0.4515	0.4065	0.4613	0.4054
0.4656	0.4149	0.4555	0.4152	0.4515	0.4059	0.4615	0.4056
0.4656	0.4155	0.4553	0.4149	0.4515	0.4053	0.4618	0.4059
0.4655	0.4162	0.4550	0.4146	0.4515	0.4046	0.4620	0.4062
0.4654	0.4168	0.4548	0.4143	0.4517	0.4040	0.4622	0.4065
0.4651	0.4174	0.4546	0.4141	0.4519	0.4034	0.4624	0.4067
0.4648	0.4180	0.4544	0.4138	0.4523	0.4028	0.4626	0.4070
0.4644	0.4184	0.4542	0.4135	0.4527	0.4024	0.4628	0.4073
0.4638	0.4188	0.4541	0.4132	0.4532	0.4020	0.4630	0.4076
0.4633	0.4190	0.4539	0.4130	0.4538	0.4018	0.4632	0.4078
0.4626	0.4191	0.4537	0.4127	0.4544	0.4017	0.4634	0.4081
0.4620	0.4192	0.4535	0.4124	0.4551	0.4016	0.4635	0.4084
0.4613	0.4191	0.4533	0.4121	0.4557	0.4017	0.4637	0.4087
0.4607	0.4189	0.4532	0.4118	0.4563	0.4019	0.4639	0.4090
0.4601	0.4187	0.4530	0.4115	0.4569	0.4021	0.4640	0.4093
0.4595	0.4184	0.4528	0.4111	0.4575	0.4024	0.4642	0.4097
0.4590	0.4181	0.4527	0.4108	0.4580	0.4027	0.4644	0.4100

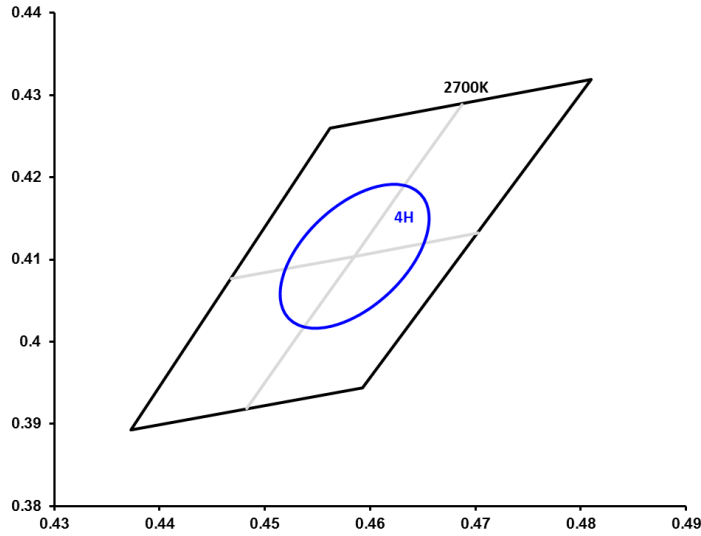
Color Bin Structure

Fig 11. CIE Chromaticity Diagram

2700K 4Step

4H							
CIE X	CIE Y	CIE X	CIE Y	CIE X	CIE Y	CIE X	CIE Y
0.4645	0.4104	0.4585	0.4178	0.4525	0.4104	0.4585	0.4030
0.4647	0.4108	0.4581	0.4175	0.4524	0.4100	0.4590	0.4033
0.4648	0.4112	0.4577	0.4172	0.4522	0.4096	0.4594	0.4036
0.4650	0.4116	0.4573	0.4169	0.4521	0.4092	0.4598	0.4039
0.4651	0.4121	0.4569	0.4166	0.4519	0.4087	0.4601	0.4042
0.4653	0.4126	0.4566	0.4163	0.4518	0.4082	0.4604	0.4045
0.4654	0.4131	0.4563	0.4160	0.4517	0.4077	0.4607	0.4048
0.4655	0.4137	0.4560	0.4157	0.4516	0.4071	0.4610	0.4051
0.4656	0.4143	0.4558	0.4154	0.4515	0.4065	0.4613	0.4054
0.4656	0.4149	0.4555	0.4152	0.4515	0.4059	0.4615	0.4056
0.4656	0.4155	0.4553	0.4149	0.4515	0.4053	0.4618	0.4059
0.4655	0.4162	0.4550	0.4146	0.4515	0.4046	0.4620	0.4062
0.4654	0.4168	0.4548	0.4143	0.4517	0.4040	0.4622	0.4065
0.4651	0.4174	0.4546	0.4141	0.4519	0.4034	0.4624	0.4067
0.4648	0.4180	0.4544	0.4138	0.4523	0.4028	0.4626	0.4070
0.4644	0.4184	0.4542	0.4135	0.4527	0.4024	0.4628	0.4073
0.4638	0.4188	0.4541	0.4132	0.4532	0.4020	0.4630	0.4076
0.4633	0.4190	0.4539	0.4130	0.4538	0.4018	0.4632	0.4078
0.4626	0.4191	0.4537	0.4127	0.4544	0.4017	0.4634	0.4081
0.4620	0.4192	0.4535	0.4124	0.4551	0.4016	0.4635	0.4084
0.4613	0.4191	0.4533	0.4121	0.4557	0.4017	0.4637	0.4087
0.4607	0.4189	0.4532	0.4118	0.4563	0.4019	0.4639	0.4090
0.4601	0.4187	0.4530	0.4115	0.4569	0.4021	0.4640	0.4093
0.4595	0.4184	0.4528	0.4111	0.4575	0.4024	0.4642	0.4097
0.4590	0.4181	0.4527	0.4108	0.4580	0.4027	0.4644	0.4100

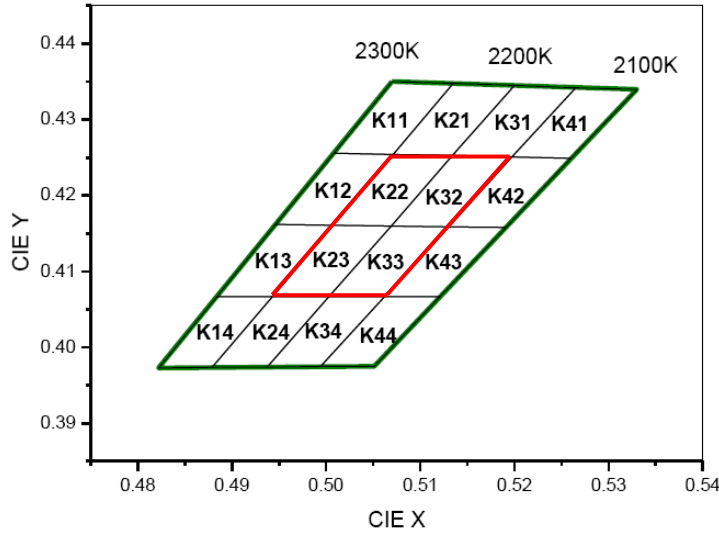
Color Bin Structure

Fig 12. CIE Chromaticity Diagram

K11		K21		K31		K41	
CIE x	CIE y	CIE x	CIE y	CIE x	CIE y	CIE x	CIE y
0.5070	0.4350	0.5135	0.4348	0.5200	0.4345	0.5265	0.4342
0.5008	0.4256	0.5071	0.4254	0.5134	0.4253	0.5197	0.4251
0.5071	0.4254	0.5134	0.4253	0.5197	0.4251	0.5260	0.4249
0.5135	0.4348	0.5200	0.4345	0.5265	0.4342	0.5330	0.4340
K12		K22		K32		K42	
CIE x	CIE y	CIE x	CIE y	CIE x	CIE y	CIE x	CIE y
0.5008	0.4256	0.5071	0.4254	0.5134	0.4253	0.5197	0.4251
0.4946	0.4162	0.5007	0.4161	0.5069	0.4160	0.5130	0.4159
0.5007	0.4161	0.5069	0.4160	0.5130	0.4159	0.5191	0.4158
0.5071	0.4254	0.5134	0.4253	0.5197	0.4251	0.5260	0.4249
K13		K23		K33		K43	
CIE x	CIE y	CIE x	CIE y	CIE x	CIE y	CIE x	CIE y
0.4946	0.4162	0.5007	0.4161	0.5069	0.4160	0.5130	0.4159
0.4884	0.4067	0.4943	0.4067	0.5003	0.4067	0.5062	0.4067
0.4943	0.4067	0.5003	0.4067	0.5062	0.4067	0.5121	0.4067
0.5007	0.4161	0.5069	0.4160	0.5130	0.4159	0.5191	0.4158
K14		K24		K34		K44	
CIE x	CIE y	CIE x	CIE y	CIE x	CIE y	CIE x	CIE y
0.4884	0.4067	0.4943	0.4067	0.5003	0.4067	0.5062	0.4067
0.4822	0.3973	0.4879	0.3974	0.4937	0.3974	0.4994	0.3975
0.4879	0.3974	0.4937	0.3974	0.4994	0.3975	0.5051	0.3975
0.4943	0.4067	0.5003	0.4067	0.5062	0.4067	0.5121	0.4067

Mechanical Dimensions

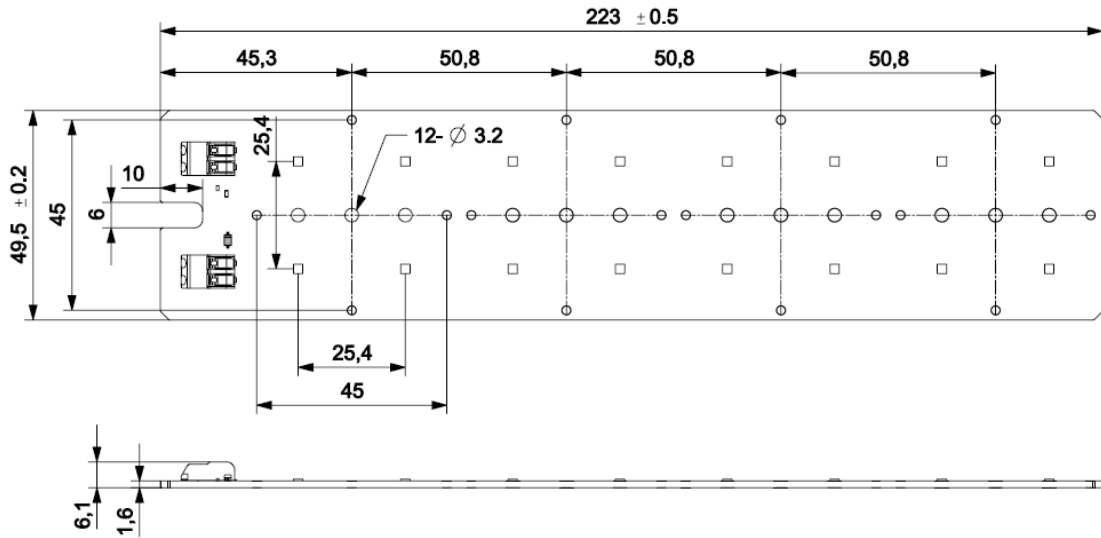

Circuit Drawing

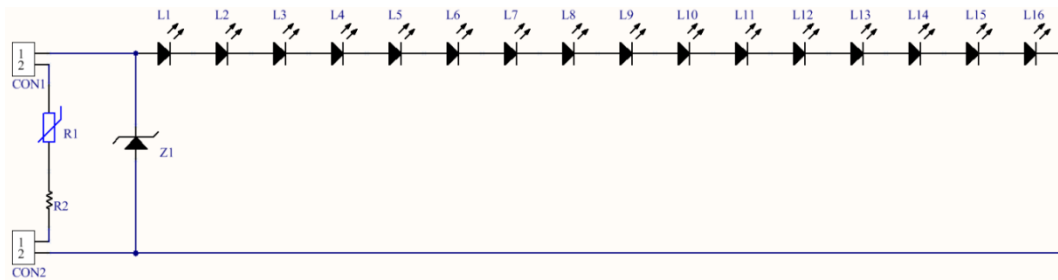

Notes :

- (1) All dimensions are in millimeters.
- (2) Scale : None
- (3) Module thickness : 1.6 ± 0.1

Application Information

a). Connection between driver and module

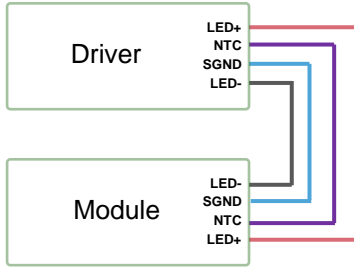

b). Multiple module on one driver

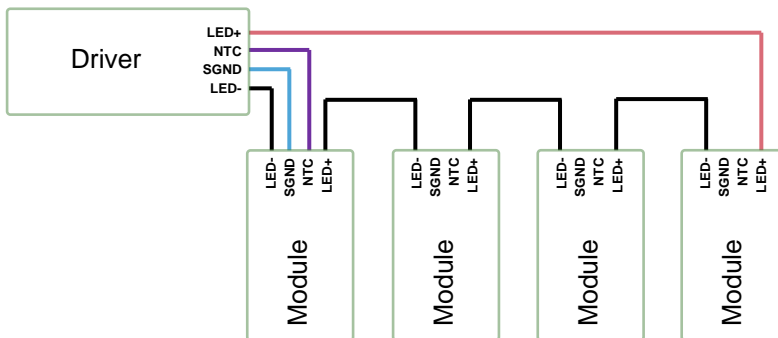

c). To use a driver with multi output channels for group application

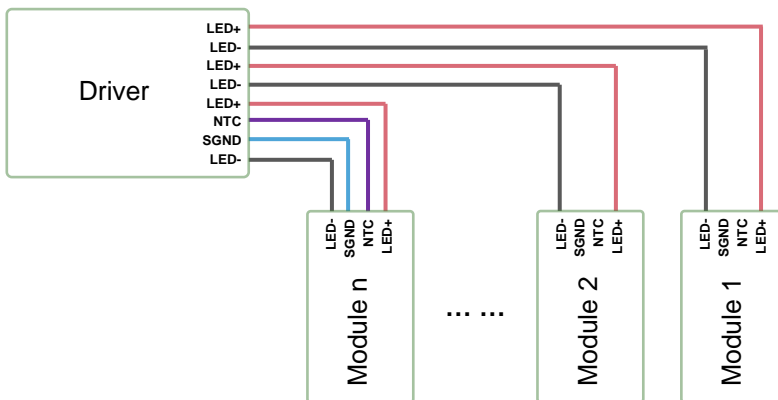

Notes :

- (1) In case of all modules have to be in parallel for a group application, 3 is the max quantity in parallel.

Application Information

a). Application

IP rating	No IP-rating
Over Temperature Detection	A resistor and NTC in series, where $R=2K\Omega$, $R_{NTC}=15K\Omega$
Luminaire Class	IEC Class I and Class II
Dimming	Yes

b). Certificates and Standards

UL 8750
CE

Product Nomenclature

Product Name Rule:

S M J D - 48 35 016 K - XX N 1
 ① ② ③ ④ ⑤ ⑥ ⑦ ⑧

①: SMJD – Seoul DC Module
 ② ~ ⑧: Refer to below table

Voltage				Power				LED Qty.						LED Type		Customer (Free)		Dimming		Etc. (Free)	
②		③		④						⑤		⑥		⑦		⑧					
4	8	3	5	0	1	6	K		XX		N		1								
0	0	0	0	0	0	0	0	0	0	0	0	0	L	Y22	XX	Reference	N	Normal	1	Version	
1	10V	1	1V	1	10W	1	1W	1	100EA	1	10EA	1	1EA	K	Y19			D	Dimming		
2	20V	2	2V	2	20W	2	2W	2	200EA	2	20EA	2	2EA					E	Etc.		
3	30V	3	3V	3	30W	3	3W	3	300EA	3	30EA	3	3EA								
...									
9	90V	9	9V	9	90W	9	9W	9	900EA	9	90EA	9	9EA								
A	100V			A	100W			A	1000EA												
B	110V			B	110W																
...																
Z	350V			Z	350W																

Comments Rule:

(00 W0 70)
A B C

Lens Type		CCT		CRI	
A		B		C	
00		W0		70	
00	No lens	W0	6500K	70	CRI70
			5700K	80	CRI80
		WN	5000K		
			4000K		
		WW	3000K		
			2700K		
			2200K		

Product Nomenclature

Characteristics Rule:

00 E77 E04 7 All
A **B** **C** **D** **E**

Lens Type		Flux Bin		CCT Bin		CRI Bin		VF Bin ⁽¹⁾	
A		B		C		D		E	
		E77		E04		7		ALL	
00	No lens	E77	4770 lm	A04	6500K 4-step	7	CRI70	ALL	VF: ALL
		E55	4550 lm	B04	5700K 4-step	8	CRI80		
		E05	4050 lm	C04	5000K 4-step				
		D11	3110 lm	E04	4000K 4-step				
		D78	3780 lm	G04	3000K 4-step				
				H04	2700K 4-step				
				K04	2200K 4-step				

Marking Information

Fig 13. Marking Point

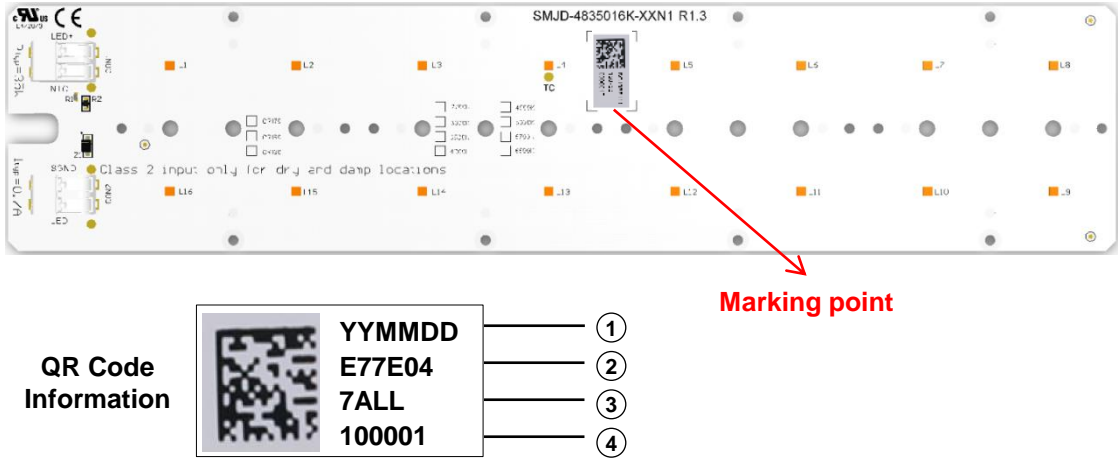

QR Code Information								
Items	Factory	SAP Code	SMT Date	Rank Information	Line No.	Lot No.	Product	Notes
Digits	1 Digit	7 Digit	6 Digit	10 Digit	1 Digit	1 Digit	5 Digit	In Total 31 Digits
Information	*	*****	YYMMDD D	E77E04 7ALL	1~9, A~Z	1~9, A~Z	00001	

Plain Code Information

No.	Item	Information	Digits	Remark
①	Date	YYMMDD	6Digit	SMT date
②	Flux ⁽¹⁾	E77	3Digit	E77=4770lm
	CCT	X04 4- step	3Digit	X= A,B,C,E,G,H,K
③	CRI	7	1Digit	CRI=70
		8	1Digit	CRI=80
	V _F	ALL	3Digit	V _F : ALL
④	Lot No.	1	1 Digit	0~9,A~Z
	Sequence No.	00001	5 Digit	00001 ~ 99999











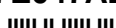
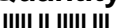

Notes :

This product 4-step mixing can use different flux Bin

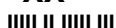
(1) Module Flux code rule as below table

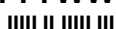
Symbol	Im	Symbol	Im	Symbol	Im	Symbol	Im
E77	4770	O50	14500	R50	17500	U50	20500
M20	12200	P50	15500	S50	18500	V20	21200
N00	13000	Q50	16500	T50	19500	W00	22000

Label Information

PO Number 	XXXXXX (1) 
Part Number 	SMJD-4835016K-XXN100E77E047ALL (2) 
Bin Code 	E77E047ALL (3) 
Quantity 	XX 
Country of Origin 	XX (4) 
Date Code 	YYYYWW (5) 
Lot Code 	YYMDDXXXXX- XXXXXXXX (6) 
	Kwangmyung Semiconductor (TianJin) Co Ltd

Notes

- (1) This is customer's PO Number
- (2) Please refer to SPEC page 2 (30 digit code)
- (3) Please refer to SPEC page 22
- (4) Country of Origin: 2 digit code . For example : Chinese Code: CN
- (5) Date Code : YYYYWW : Packing Date: Year + Week
- (6) Lot Code :
 Initial of manufacture is refer to the 2D code rule.
 YYMDD : Packing Date (Oct. : A, Nov. : B, Dec. : C)
 X : Initial of Manufacturer
 XXXX : Sealing Pack No.
 XXXXXXXX : SSC SAP Code
- (7) It is attached to the top left corner of the box.

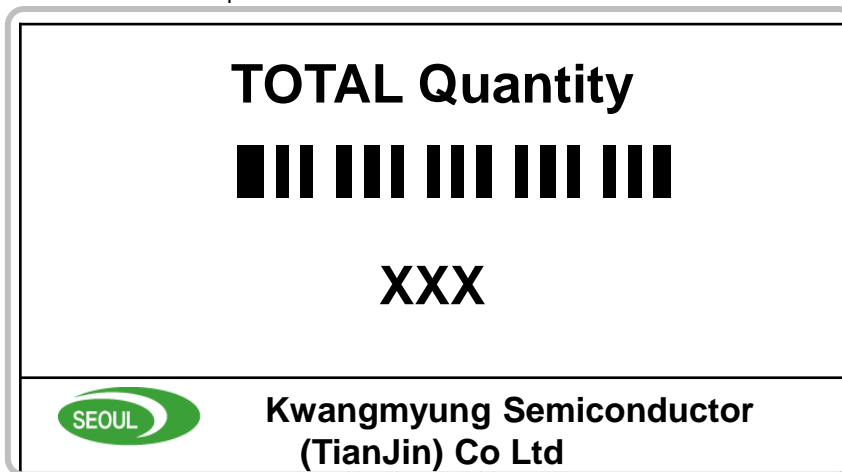
Notes

- (1) It is attached to the bottom right corner of the carton box.

Packaging Specification

1. Tray information

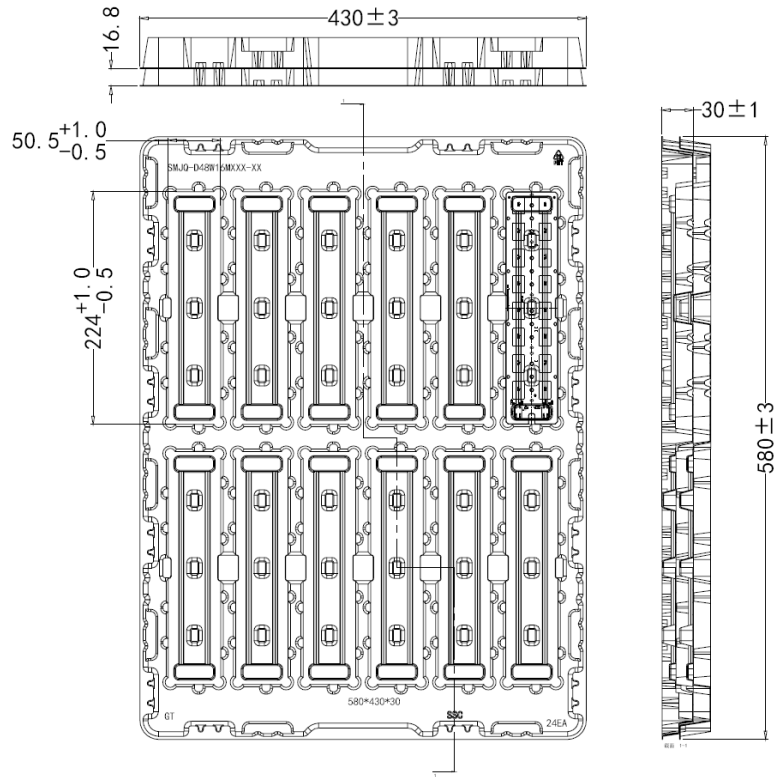

Notes:

- (1) Quantity : 24 pcs/Tray
- (2) All dimensions are in millimeters (tolerance : ± 0.3)
- (3) Scale none

2. Tray stack and taping

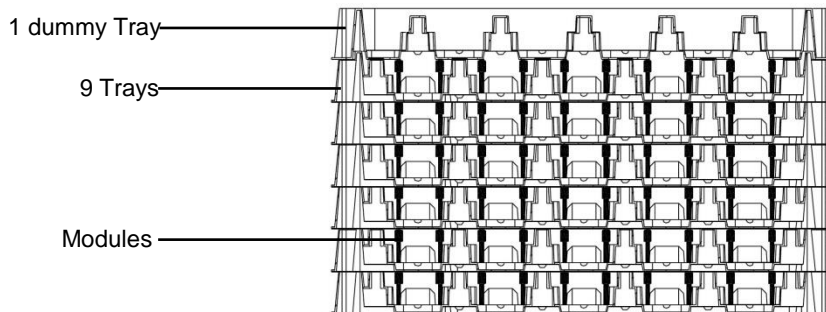

Notes:

- (1) 9 Trays and additional 1 dummy tray up of box

Packaging Specification

3. Box information & packing

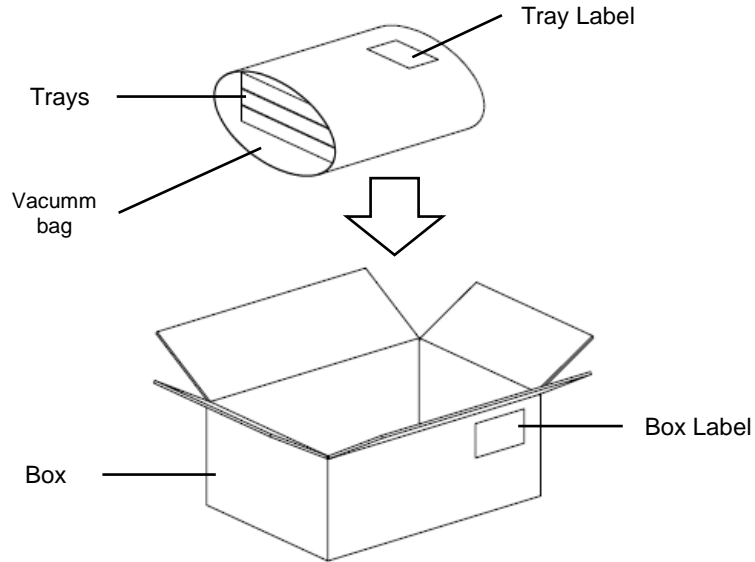

Notes:

- (1) Quantity: 9Trays (9*24=216pcs) / Box
- (2) Box size: 590*440*200 mm

4. Pallet information & packing

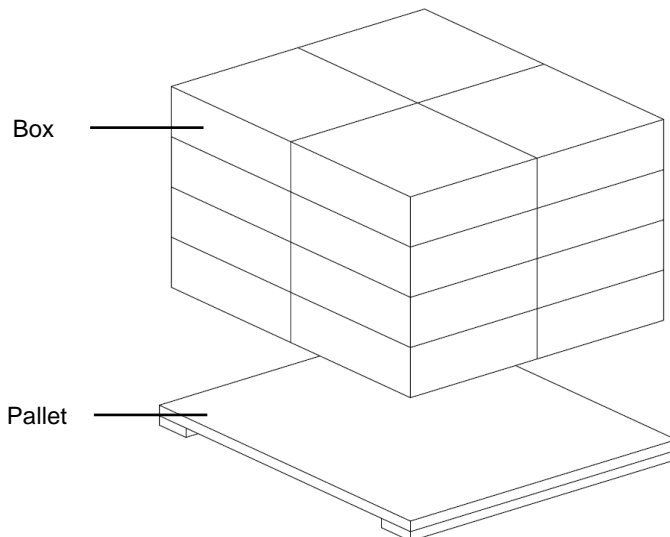

Notes:

- (1) Quantity: 1 Pallet = 20(4*5) Boxes = 180(20*9) Trays = 4,320(180*24) Modules
- (2) Pallet size: 1100*1100*12.5mm

Precaution for Use

- (1) Check the appearance of module before wiring/ assembly, DO NOT use the LED cracked or PCB damaged module.
- (2) The module was designed to be driven with DC source, recognize the polarities of the module was necessity.
- (3) It was SELV module, DO NOT connect the LED directly to main power during wiring.
- (4) DO NOT let the LED packages contacted with any hard matters.
- (5) There was no current regulator built in module, unevenly load between different parallel modules may occur due to the modules V_F variance .
- (6) Please do not use together with the materials containing Sulfur.
- (7) Please do not make any modification on module.

Precaution for Use

(8) LEDs are sensitive to Electro-Static Discharge (ESD) and Electrical Over Stress (EOS).

Below is a list of suggestions that Seoul Semiconductor purposes to minimize these effects.

a. ESD (Electro Static Discharge)

Electrostatic discharge (ESD) is defined as the release of static electricity when two objects come into contact. While most ESD events are considered harmless, it can be an expensive problem in many industrial environments during production and storage. The damage from ESD to an LEDs may cause the product to demonstrate unusual characteristics such as:

- Increase in reverse leakage current lowered turn-on voltage
- Abnormal emissions from the LED at low current

The following recommendations are suggested to help minimize the potential for an ESD event:

One or more recommended work area suggestions:

- Ionizing fan setup
- ESD table/shelf mat made of conductive materials
- ESD safe storage containers

One or more personnel suggestion options:

- Antistatic wrist-strap
- Antistatic material shoes
- Antistatic clothes

Environmental controls

- Humidity control (ESD gets worse in a dry environment)

b. EOS (Electrical Over Stress)

Electrical Over-Stress (EOS) is defined as damage that may occur when an electronic device is subjected to a current or voltage that is beyond the maximum specification limits of the device.

The effects from an EOS event can be noticed through product performance like:

Changes to the performance of the LED package (If the damage is around the bond pad area and since the package is completely encapsulated the package may turn on but flicker show severe performance degradation.)

Changes to the light output of the luminaire from component failure

Components on the board not operating at determined drive power

Failure of performance from entire fixture due to changes in circuit voltage and current across total circuit causing trickle down failures

It is impossible to predict the failure mode of every LED exposed to electrical overstress as the failure modes have been investigated to vary, but there are some common signs that will indicate an EOS event has occurred.

- Damaged may be noticed to the bond wires (appearing similar to a blown fuse).
- Damage to the bond pads located on the emission surface of the LED package (shadowing can be noticed around the bond pads while viewing through a microscope).
- Anomalies noticed in the encapsulation and phosphor around the bond wires.
- This damage usually appears due to the thermal stress produced during the EOS event.

c. To help minimize the damage from an EOS event Seoul Semiconductor recommends utilizing

- qualified LED driver with no big over shoot out put
- Isolated driver that to prevent harmful peaks passed to module.
- A current limiting device

Storage before use

- (1) Do not impact or place pressure on this product because even a small amount of pressure can damage the product. The product should also not be placed in high temperatures, high humidity or direct sunlight since the device is sensitive to these conditions.
- (2) When storing devices for a long period of time before usage, please following these guidelines:
 - * The devices should be stored in the anti-static bag that it was shipped in from Seoul-Semiconductor with opening.
 - * If the anti-static bag has been opened, re-seal preventing air and moisture from being present in the bag.

Guidelines for properly working with Module

- (1) Discharge the lighting system a minimum of 2-3 times prior to working with the module.
- (2) Use only properly rated test equipment and tools for the rated voltage and current of the product being tested.
- (3) It is strongly suggested to wear rubber insulated gloves and rubber bottom shoes.
- (4) Do not wear any conductive items (such as jewelry) which could accidentally contact electric circuits.
- (5) Perform several tests with power off and the lighting system unplugged.
- (6) Faults, lightning, or switching transients can cause voltage surges in excess of the normal ratings.
- (7) Internal component failure can cause excessive voltages.
- (8) Stored or residual electricity in long wire could be hazardous.
- (9) Make sure proper discharge prior to starting work.

Company Information

Published by

Seoul Semiconductor © 2013 All Rights Reserved.

Company Information

Seoul Semiconductor (SeoulSemicon.com) manufactures and packages a wide selection of light emitting diodes (LEDs) for the automotive, general illumination/lighting, appliance, signage and back lighting markets. The company is the world's fifth largest LED supplier, holding more than 10,000 patents globally, while offering a wide range of LED technology and production capacity in areas such as "nPola", deep UV LEDs, "Acrich", the world's first commercially produced AC LED, and "Acrich MJT - Multi-Junction Technology" a proprietary family of high-voltage LEDs. The company's broad product portfolio includes a wide array of package and device choices such as Acrich, high-brightness LEDs, mid-power LEDs, side-view LEDs, through-hole Type LED lamps, custom displays, and sensors. The company is vertically integrated from epitaxial growth and chip manufacture in its fully owned subsidiary, Seoul Viosys, through packaged LEDs and LED modules in three Seoul Semiconductor manufacturing facilities. Seoul Viosys also manufactures a wide range of unique deep-UV wavelength devices.

Legal Disclaimer

Information in this document is provided in connection with Seoul Semiconductor products. With respect to any examples or hints given herein, any typical values stated herein and/or any information regarding the application of the device, Seoul Semiconductor hereby disclaims any and all warranties and liabilities of any kind, including without limitation, warranties of non-infringement of intellectual property rights of any third party. The appearance and specifications of the product can be changed to improve the quality and/or performance without notice.

Revision History

Revision	Date	Page	Remarks
R0.1	2018.06.15	All	
R0.2	2018.07.24	Page10~14	Updating CIE Chromaticity Diagram
R0.3	2018.10.29	All	Added Order Code
R0.4	2019.03.25	All	Updating Absolute Maximum Ratings
R0.5	2019.07.15	All	Added 2200K CCT
R0.6	2019.10.09	All	Added the curve of Flux and Efficacy Versus Temperature
R0.7	2019.12.09	All	Added CRI70 H and K rank